

## Note to Online Reader

This manual has been altered from the original to protect Xantrex's intellectual property.

The replacement parts lists and schematics have been removed. If you wish to receive a complete printed copy of this manual, please call Xantrex Sales and Support at 1-800-667-8422 (in North America) or send e-mail to [sales@xantrex.com](mailto:sales@xantrex.com).

## Confidential Information

The information contained in this document is confidential and is the exclusive property of Xantrex Technology Inc. It may not be disclosed to any person without the express written consent of Xantrex Technology Inc.

[View Manual](#)



### **NOTE TO ONLINE READER**

This manual has been altered from the original to protect Xantrex's intellectual property.

The replacement parts lists and schematics have been removed. If you wish to receive a complete printed copy of this manual, please call Xantrex Sales and Support at 1-800-667-8422 (in North America) or send e-mail to [sales@xantrex.com](mailto:sales@xantrex.com).

#### **Confidential Information**

The information contained in this document is confidential and is the exclusive property of Xantrex Technology Inc. It may not be disclosed to any person without the express written consent of Xantrex Technology Inc.

## **Operating Manual for**

## **XFR SERIES Power Supply**

**This manual covers  
2800 Watt models:**

<b>7.5-300</b>	<b>100-28</b>
<b>12-220</b>	<b>150-18</b>
<b>20-130</b>	<b>300-9</b>
<b>40-70</b>	<b>600-4</b>
<b>60-46</b>	

## WARRANTY

This unit is guaranteed for five (5) years from the date of delivery against defects in material and workmanship. This does not apply to products damaged through accident, abuse, misuse, or unauthorized repair. The manufacturer shall not be liable for any special or consequential damage of any nature. The manufacturer will repair or replace the non-conforming product or issue credit, at its option, provided the manufacturer's inspection establishes the existence of a defect. Packing, freight, insurance and other charges incurred in returning the defective products to the manufacturer will be paid by the purchaser. The manufacturer will pay return freight if the repaired unit is deemed to be under warranty. If any questions arise concerning the warranty, check with the manufacturer prior to taking any action.

When requesting information, assistance, or authorization, please state the serial number of the unit, available from the label on the unit. Give a brief description of the problem with the unit. For information about packaging for shipping, see Section 2.3.3.

## GENERAL WARNINGS AND CAUTIONS



### HIGH ENERGY AND HIGH VOLTAGE WARNINGS

Exercise caution when using and servicing a power supply. High energy levels can be stored at the output voltage terminals on a power supply in normal operation. In addition, potentially lethal voltages exist in the power circuit and on the output and sense connectors of a power supply with a rated output greater than 40V. Filter capacitors store potentially dangerous energy for some time after power is removed.

### OPERATING AND SERVICE PRECAUTIONS

Operate the power supply in an environment free of flammable gases or fumes. To ensure that the power supply's safety features are not compromised, use the power supply as specified in this manual and do not substitute parts or make any unauthorized modifications. Contact the service technician for service and repair help. Repairs must be made by experienced service technicians only.

## POWER SUPPLY SAFETY MARKINGS



Protective Conductor Terminal



Caution (Check manual for details.)

## CONFIDENTIAL INFORMATION

The information contained in this document is confidential and is the exclusive property of Xantrex Technology Inc. It may not be disclosed to any person without the express written consent of Xantrex Technology Inc.

## ABOUT THIS MANUAL

This OPERATING MANUAL contains user information for the XFR Series of variable DC output power supplies, which are available in several voltage models at 2800 Watts. It provides information about features and specifications, installation procedures, and basic functions testing, as well as operating procedures for using both front panel control and remote analog programming functions.

### Who Should Use This Manual

This manual is designed for the user who is familiar with basic electrical laws especially as they apply to the operation of power supplies. This implies a recognition of Constant Voltage and Constant Current operating modes and the control of input and output power, as well as the observance of safe techniques while effecting supply or pin connections and any changes in switch settings. The more technical user can refer to the schematics in the service manual for troubleshooting and for configuring new applications.

<b>Section 1. Features and Specifications</b>	Describes the power supply and lists its features and specifications.
<b>Section 2. Installation</b>	Goes through basic setup procedures. Describes inspection, cleaning, shipping, and storage procedures. Includes AC input connection, basic functions testing, and load and sense lines connections.
<b>Section 3. Local Operation</b>	Provides procedures for local (front panel) operation. Includes procedures for using over voltage protection, shutdown function, multiple supplies, and over temperature protection.
<b>Section 4. Remote Operation</b>	Covers remote analog programming operation and remote monitoring of output voltage and current.
<b>Section 5. Calibration</b>	Includes calibration for programming and readback accuracy.

### Manual Revisions

The current release of this manual is listed below. Insert pages will update already-printed manuals. Reprinted manuals may note any minor corrections and additions on the Manual Changes list (page ii). A new release of the manual is identified by a new release number and printing date and will include all of the additional or corrected information since the last release.

Release 1.0 (98/07/24)

### Warnings, Cautions, and Notes

Warnings, cautions, and notes are defined and formatted in this manual as shown below.

<b>WARNING</b>
Describes a potential hazard which could result in injury or death, or, a procedure which, if not performed correctly, could result in injury or death.

<b>CAUTION</b>
Describes a procedure which, if not performed correctly, could result in damage to data, equipment, or systems.

Note: Describes additional operating information which may affect the performance of the equipment.

## **MANUAL CHANGES**

There are no changes at this time.

# CONTENTS

About This Manual .....i  
 Manual Changes.....ii  
 Contents .....iii  
 List of Illustrations .....v  
 List of Tables .....v

## 1. FEATURES AND SPECIFICATIONS

1.1 Description .....1-1  
 1.2 Features and Options .....1-1  
 1.3 Specifications .....1-2  
     1.3.1 Electrical Specifications .....1-2  
     1.3.2 Additional Specifications .....1-4  
     1.3.3 Input Conditions .....1-4  
     1.3.4 Additional Characteristics .....1-4  
     1.3.5 Remote Programming and Monitoring .....1-5  
     1.3.6 Environmental Specification .....1-5  
     1.3.7 Mechanical Specification .....1-5

## 2. INSTALLATION

2.1 Introduction .....2-1  
 2.2 Basic Setup Procedure .....2-1  
 2.3 Inspection, Cleaning, and Packaging .....2-1  
     2.3.1 Initial Inspection .....2-1  
     2.3.2 Periodic Cleaning .....2-4  
     2.3.3 Packaging for Shipping or Storage .....2-4  
 2.4 Location, Mounting, and Ventilation .....2-5  
     2.4.1 Rack Mounting .....2-5  
     2.4.2 Ventilation .....2-5  
 2.5 AC Input Power .....2-6  
     2.5.1 AC Input Connector and Voltage Selection .....2-6  
     2.5.2 AC Input Cord .....2-6  
     2.5.3 AC Input Wire Connection .....2-7  
 2.6 Functional Tests .....2-8  
     2.6.1 Equipment Required .....2-8  
     2.6.2 Power-on Check .....2-8  
     2.6.3 Voltage Mode Operation Check .....2-8  
     2.6.4 Current Mode Operation Check .....2-9  
     2.6.5 Front Panel Function Checks .....2-9  
 2.7 Load Connection .....2-10  
     2.7.1 Load Wiring .....2-10  
     2.7.2 Making Load Connections .....2-11  
     2.7.3 Inductive Loads .....2-14  
     2.7.4 Connecting Single Loads .....2-15  
     2.7.5 Connecting Multiple Loads .....2-15  
 2.8 Local and Remote Sensing .....2-17  
     2.8.1 Sense Wiring .....2-17  
     2.8.2 Local Sensing .....2-17  
     2.8.3 Using Remote Sensing .....2-18

### 3. LOCAL OPERATION

3.1 Introduction .....	3-1
3.2 Standard Operation.....	3-1
3.2.1 Operating Modes and Automatic Crossover.....	3-1
3.2.2 Shipped Configuration (Local Control Mode) .....	3-2
3.2.3 Setting Output Voltage and Current Limit .....	3-3
3.3 Using Over Voltage Protection (OVP).....	3-4
3.3.1 Front Panel OVP Operation .....	3-4
3.3.2 Resetting the OVP Circuit.....	3-4
3.4 Using the Shutdown Function.....	3-5
3.4.1 STANDBY Switch.....	3-5
3.4.2 Controlling the Shutdown Function via the J2 Connector .....	3-5
3.5 Using Multiple Supplies .....	3-6
3.5.1 Configuring Multiple Supplies for Series Operation.....	3-6
3.5.2 Configuring Multiple Supplies for Parallel Operation .....	3-7
3.5.3 Configuring Multiple Supplies for Split Supply Operation.....	3-8
3.6 Over Temperature Protection (OTP).....	3-9
3.7 User Diagnostics.....	3-10
3.7.1 Emergency Shutdown.....	3-10
3.7.2 Unusual or Erratic Operation .....	3-10
3.7.3 Troubleshooting for Operators.....	3-11

### 4. REMOTE OPERATION

4.1 Introduction .....	4-1
4.2 Switches and Connector Used for Remote Programming and Monitoring.....	4-1
4.2.1 Rear Panel SW1 Switch .....	4-1
4.2.2 Rear Panel J2 Connector .....	4-2
4.3 Remote Analog Programming of Output Voltage and Current Limit.....	4-4
4.3.1 Remote Programming Options .....	4-4
4.3.2 Remote Analog Programming Procedure.....	4-4
4.4 Remote Monitoring of Output Voltage and Current.....	4-6
4.4.1 Readback Signals .....	4-6
4.5 Using the Isolated (ISOL) Programming Interface Option.....	4-7
4.5.1 ISOL Specifications .....	4-7
4.5.2 ISOL Setup and Operating Instructions.....	4-7
4.5.3 ISOL Calibration.....	4-7

### 5. CALIBRATION

5.1 Introduction .....	5-1
5.2 Calibration Setup.....	5-1
5.2.1 Service Environment and Precautions.....	5-1
5.2.2 Equipment Required.....	5-1
5.2.3 Accessing Calibration Potentiometers.....	5-2
5.3 Calibrating for Programming Accuracy.....	5-3
5.3.1 Voltage Programming Circuit Calibration.....	5-3
5.3.2 Current Limit Programming Circuit Calibration .....	5-3
5.4 Calibrating for Readback Accuracy.....	5-4
5.4.1 Output Voltage Monitor Circuit Calibration .....	5-4
5.4.2 Output Current Monitor Circuit Calibration.....	5-4

## LIST OF ILLUSTRATIONS

Figure 1.3-1 Typical Input Current Characteristics.....	1-4
Figure 1.3-2 Dimensional Drawings .....	1-6
Figure 2.3-1 Power Supply Front Panel .....	2-2
Figure 2.3-2 Power Supply Rear Panel .....	2-3
Figure 2.3-3 Shipping or Storage Carton Label .....	2-4
Figure 2.5-1 AC Input Label and Strain Relief .....	2-7
Figure 2.7-1 Maximum Load Wire Length for 1V Line Drop .....	2-11
Figure 2.7-2 Output Strain Relief and Bus Bar Cover .....	2-12
Figure 2.7-3 Typical Load Connection Hardware.....	2-13
Figure 2.7-4 Output Voltage Connector.....	2-14
Figure 2.7-5 Single Load with Local Sensing (Default).....	2-15
Figure 2.7-6 Single Load with Remote Sensing.....	2-15
Figure 2.7-7 Multiple Loads with Local Sensing .....	2-16
Figure 2.7-8 Multiple Loads with Remote Sensing.....	2-16
Figure 2.8-1 J10 Sense Connector .....	2-17
Figure 2.8-2 Connecting Remote Sense Lines .....	2-19
Figure 3.2-1 Operating Modes .....	3-1
Figure 3.5-1 Series Operation of Multiple Supplies.....	3-6
Figure 3.5-2 Parallel Operation of Multiple Supplies .....	3-7
Figure 3.5-3 Split Supply Operation of Multiple Supplies (Two Positive Voltages).....	3-8
Figure 3.5-4 Split Supply Operation of Multiple Supplies (Positive-negative Supply) .....	3-9
Figure 4.2-1 Programming and Monitoring SW1 Switch .....	4-1
Figure 4.2-2 Programming and Monitoring J2 Connector .....	4-2
Figure 4.3-1 Connecting Programming Sources to J2 Connector .....	4-6
Figure 5.2-1 Programming and Monitoring Calibration Locations.....	5-2

## LIST OF TABLES

Table 1.1-1 Available Voltage and Current Ranges.....	1-1
Table 1.3-1 Specifications for 7.5V to 60V Models .....	1-2
Table 1.3-2 Specifications for 100V to 600V Models .....	1-3
Table 2.2-1 Basic Setup Procedure .....	2-1
Table 2.5-1 AC Input Voltage Range and Frequency .....	2-6
Table 2.5-2 AC Wire Specification.....	2-6
Table 2.5-3 AC Input Connector Terminals and Connections .....	2-7
Table 2.7-1 Current Carrying Capacity for Load Wiring.....	2-10
Table 2.8-1 Rear Panel J10 Sense Connector Terminals and Functions .....	2-17
Table 3.2-1 Shipped Configuration (Local Control Mode).....	3-2
Table 3.4-1 Switch Settings for TTL Shutdown Circuit Logic .....	3-5
Table 3.6-1 Switch Settings for Over Temperature Recovery Options.....	3-9
Table 3.7-1 User Diagnostics.....	3-11
Table 4.2-1 Rear Panel SW1 Switch Assignments (Factory Defaults Underlined).....	4-2
Table 4.2-2 Rear Panel J2 Connector Terminals and Functions .....	4-3
Table 4.3-1 Remote Programming Options .....	4-4
Table 4.3-2 Power Supply Settings for Different Programming Sources.....	4-5
Table 4.4-1 Power Supply Settings for Remote Monitoring of Readback Signals.....	4-6
Table 4.5-1 Isolated (ISOL) Programming Interface Specifications.....	4-7
Table 5.2-1 Current Carrying Capacity for Wiring.....	5-1





# 1. FEATURES AND SPECIFICATIONS

## 1.1 Description

This series of power supplies provides low noise, precisely regulated, variable DC output at 2800 Watts of output power. Over voltage protection and thermal shutdown are standard. Front panel controls and indicators are extensive. Select from several remote control choices: standard analog programming, standard remote monitoring of output voltage and current; optional isolated programming or readback, and optional GPIB programming or RS-232 control. Use this power supply either on your bench or in a standard 19" rack: the unit occupies only 3.5" (2U) of vertical rack space. Designed for continuous use in standalone or systems applications, this power supply is typically used to power DC equipment, control magnets, or burn in components. See Table 1.1-1 for the list of available models.

<b>Model</b>	<b>Voltage Range</b>	<b>Current Range</b>
7.5-300	0-7.5V	0-300A
12-220	0-12V	0-220A
20-130	0-20V	0-130A
40-70	0-40V	0-70A
60-46	0-60V	0-46A
100-28	0-100V	0-28A
150-18	0-150V	0-18A
300-9	0-300V	0-9A
600-4	0-600V	0-4A

## 1.2 Features and Options

- Simultaneous digital display of both voltage and current.
- Ten-turn front panel voltage and current controls for high resolution setting of the output voltage and current from zero to the rated output.
- Automatic mode crossover into current or voltage mode.
- Front panel push button control of output standby mode and preview of voltage, current, or over voltage protection (OVP) setpoints. Front panel light emitting diode (LED) indicators for voltage and current mode operation, OVP, remote programming mode, and shutdown. Front panel control of OVP.
- Multiple units can be connected in parallel or series to provide increased current or voltage.
- Thermal shutdown, latching or auto reset.
- Remote analog voltage and current limit programming with selectable programming ranges.
- External monitor signals for output voltage and current.
- Isolated analog remote programming control of the output voltage or current and isolated readback of output voltage and current with the optional ISOL Interface.
- Optional internal GPIB or RS-232 computer control for remote digital programming and readback capability.
- Rack mount brackets at the front panel are standard.

## 1.3 Specifications

### 1.3.1 Electrical Specifications

These specifications are warranted over a temperature range of 0°C to 50°C. Nominal ambient temperature assumed is 25°C. Nominal line voltage is 208Vac, 60Hz. Table 1.3-1 and Table 1.3-2 post maximum values for model-dependent specifications. Specifications are subject to change without notice.

<b>Table 1.3-1 Specifications for 7.5V to 60V Models</b>						
<b>Models</b>		<b>7.5-300</b>	<b>12-220</b>	<b>20-130</b>	<b>40-70</b>	<b>60-46</b>
Output Ratings:	Output Voltage 1	0-7.5V	0-12V	0-20V	0-40V	0-60V
	Output Current	0-300A	0-220A	0-130A	0-70A	0-46A
	Output Power	2250W	2640W	2600W	2800W	2760W
Line Regulation: 2						
	Voltage (0.01% of Vmax + 2mV)	2.75mV	3.2mV	4mV	6mV	8mV
	Current (0.01% of Imax + 2mA)	32mA	24mA	15mA	9mA	6.6mA
Load Regulation: 3						
	Voltage (0.02% of Vmax + 5mV)	6.5mV	7.4mV	9mV	13mV	17mV
	Current (0.02% of Imax + 5mA)	65mA	49mA	31mA	19mA	14.2mA
Meter Accuracy:						
	Voltage (1% of Vmax + 1 count)	0.09V	0.13V	0.3V	0.5V	0.7V
	Current (1% of Imax + 1 count)	4A	2.3A	1.4A	0.8A	0.56A
Output Noise (0-20MHz): Voltage (p-p)						
		100mV	100mV	100mV	150mV	150mV
Output Ripple (rms):						
	Voltage	10mV	10mV	10mV	15mV	15mV
	Current 4	1600mA	1200mA	400mA	200mA	100mA
Drift (30 minutes): 5						
	Voltage (0.05% of Vmax)	3.75mV	6mV	10mV	20mV	30mV
	Current (0.6% of Vmax)	1800mA	1320mA	780mA	420mA	276mA
For Resistive Programming:						
	Voltage (0.6% of Vmax)	45mV	72mV	120mV	240mV	360mV
	Current (0.6% of Imax)	1800mA	1320mA	780mA	420mA	276mA
Drift (8 hours): 6						
	Voltage (0.05% of Vmax)	3.75mV	6mV	10mV	20mV	30mV
	Current (0.05% of Imax)	150mA	110mA	65mA	35mA	23mA
For Resistive Programming:						
	Voltage (0.3% of Vmax)	22.5mV	36mV	60mV	120mV	180mV
	Current (0.3% of Imax)	900mA	660mA	390mA	210mA	138mA
Temperature Coefficient: 7						
	Voltage (0.02% of Vmax/°C)	1.5mV	2.4mV	4mV	8mV	12mV
	Current (0.03% of Imax/°C)	90mA	66mA	39mA	21mA	13.8mA
For Resistive Programming:						
	Voltage (0.06% of Vmax/°C)	4.5mV	7.2mV	12mV	24mV	36mV
	Current (0.06% of Imax/°C)	180mA	132mA	78mA	42mA	28mA
OVP Adjustment Range:						
	(5% to 110% of Vmax)	0.375-8.25V	0.6-13.2V	1-22V	2-44V	3-66V
Efficiency: 8						
		0.80	0.82	0.85	0.87	0.90

- 1 Minimum output voltage is <0.15% of rated voltage at zero output setting.
- 2 For input voltage variation over the AC input voltage range, with constant rated load.
- 3 For 0-100% load variation, with constant nominal line voltage.
- 4 Current mode noise is measured from 10% to 100% of rated output voltage, full current.
- 5 Maximum drift over 30 minutes with constant line, load, and temperature, after power on.
- 6 Maximum drift over 8 hours with constant line, load, and temperature, after 30-minute warm-up.
- 7 Change in output per °C change in ambient temperature, with constant line and load.
- 8 Typical efficiency at nominal input voltage and full output power.

**1.3.1 Electrical Specifications (continued)**

<b>Table 1.3-2 Specifications for 100V to 600V Models</b>					
<b>Models</b>		<b>100-28</b>	<b>150-18</b>	<b>300-9</b>	<b>600-4</b>
Output Ratings:	Output Voltage 1	0-100V	0-150V	0-300V	0-600V
	Output Current	0-28A	0-18A	0-9A	0-4A
	Output Power	2800W	2700W	2700W	2400W
Line Regulation: 2					
	Voltage (0.01% of Vmax + 2mV)	12mV	17mV	32mV	62mV
	Current (0.01% of Imax + 2mA)	4.8mA	3.8mA	2.9mA	2.4mA
Load Regulation: 3					
	Voltage (0.02% of Vmax + 5mV)	27mV	35mV	65mV	125mV
	Current (0.02% of Imax + 5mA)	10.6mA	8.6mA	6.8mA	5.8mA
Meter Accuracy:					
	Voltage (1% of Vmax + 1 count)	1.1V	1.6V	4V	7V
	Current (1% of Imax + 1 count)	0.38A	0.19A	0.1A	0.05A
Output Noise (0-20MHz): Voltage (p-p)					
		175mV	200mV	400mV	500mV
Output Ripple (rms): Voltage					
		25mV	25mV	40mV	100mV
Current 4					
		80mA	40mA	20mA	10mA
Drift (30 minutes): 5					
	Voltage (0.05% of Vmax)	50mV	75mV	150mV	300mV
	Current (0.6% of Vmax)	168mA	108mA	54mA	24mA
For Resistive Programming:					
	Voltage (0.6% of Vmax)	600mV	900mV	1800mV	3600mV
	Current (0.6% of Imax)	168mA	108mA	54mA	24mA
Drift (8 hours): 6					
	Voltage (0.05% of Vmax)	50mV	75mV	150mV	300mV
	Current (0.05% of Imax)	14mA	9mA	4.5mA	2mA
For Resistive Programming:					
	Voltage (0.3% of Vmax)	300mV	450mV	900mV	1800mV
	Current (0.3% of Imax)	84mA	54mA	27mA	12mA
Temperature Coefficient: 7					
	Voltage (0.02% of Vmax/°C)	20mV	30mV	60mV	120mV
	Current (0.03% of Imax/°C)	8.4mA	5.4mA	2.7mA	1.2mA
For Resistive Programming:					
	Voltage (0.06% of Vmax/°C)	60mV	90mV	180mV	360mV
	Current (0.06% of Imax/°C)	16.8mA	10.8mA	5.4mA	2.4mA
OVP Adjustment Range:					
	(5% to 110% of Vmax)	5-110V	7.5-165V	15-330V	30-660V
Efficiency: 8					
		0.90	0.90	0.91	0.91

- 1 Minimum output voltage is <0.15% of rated voltage at zero output setting.
- 2 For input voltage variation over the AC input voltage range, with constant rated load.
- 3 For 0-100% load variation, with constant nominal line voltage.
- 4 Current mode noise is measured from 10% to 100% of rated output voltage, full current.
- 5 Maximum drift over 30 minutes with constant line, load, and temperature, after power on.
- 6 Maximum drift over 8 hours with constant line, load, and temperature, after 30-minute warm-up.
- 7 Change in output per °C change in ambient temperature, with constant line and load.
- 8 Typical efficiency at nominal input voltage and full output power.

**1.3.2 Additional Specifications**

Rise Time (No Load, Full Load): 1	7.5V to 60V models: 100 ms; 100V to 600V models: 170 ms
Fall Time (No Load): 2	4 s
Fall Time (Full Load): 3	7.5V to 60V models: 100 ms; 100V to 600V models: 170 ms
Voltage Mode Transient Response: 4	<3 ms
Time Delay from power on until output stable	7 seconds maximum

**1.3.3 Input Conditions**

AC Input Voltage Ranges	190-264Vac, 1 $\phi$ (24.3A maximum at 208Vac; 22.4A maximum at 230Vac)
Source Frequency	47-63Hz
Power Factor	0.65 typical

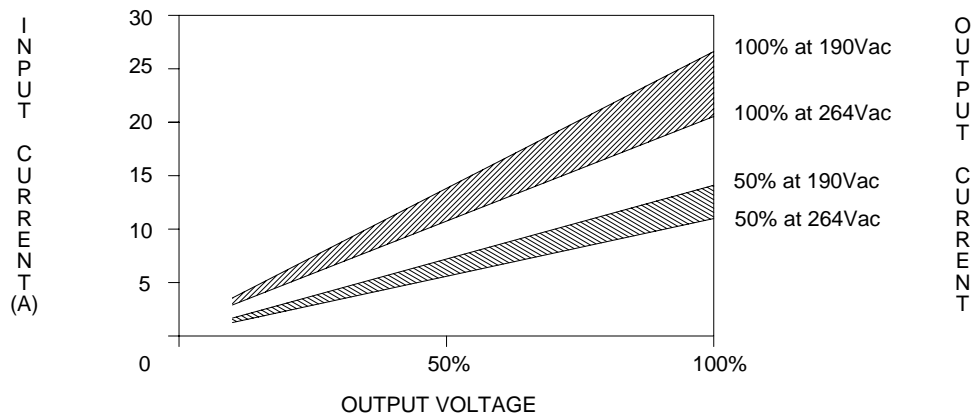

**Figure 1.3-1 Typical Input Current Characteristics**  
(Based on 100V, 28A model.)

**1.3.4 Additional Characteristics**

Switching Frequency	Nominal 31kHz (62kHz output ripple)
Output Hold-up Time	Greater than 10 ms with interruption of AC line, for nominal AC input and full load
Maximum Voltage Differential from either output to safety ground	600Vdc

1 Measured with stepped 0-10V analog programming source and a resistive load.  
 2 Measured with stepped 0-10V analog programming source and a resistive load.  
 3 Measured with stepped 0-10V analog programming source and a resistive load.  
 4 Time for the output voltage to recover within 0.5% of its previous level after a step change in load current of 10% to 90% of rated output. Load slew rate <6A/ $\mu$ s.

### 1.3.5 Remote Programming and Monitoring

Remote Analog Programming (Full Scale Input)	Voltage and current programming: 0-5k, 0-10k resistances; 0-5V, 0-10V voltage sources
Remote Monitoring	Output voltage and current: 0-5V, 0-10V 0 to full scale output 1% accuracy.
Maximum Remote Sense Line Drop Compensation	5V/line (Line drop is subtracted from total voltage available at supply output.)
Remote Start/Stop and Interlock	2.5-15V signal or TTL-compatible input, selectable logic
Optional Isolated Program and Readback (V&I)	0-5V (ISOL Interface)
Optional Digital Control	RS-232, GPIB Interfaces

### 1.3.6 Environmental Specification

Operating Temperature Range	0°C to 50°C
Storage Temperature Range	-20°C to +70°C
Humidity Range	30% to 90% RH Non-condensing
Operating Altitude	Derate maximum operating temperature by 1°C per 1,000 feet (300 m) for operation between 5,000 feet (1500 m) and 15,000 feet (4500 m).
Storage Altitude	Up to 50,000 feet (15 000 m).
Installation Category	Intended for use in installation category (overvoltage category) II (IEC 1010-1 standard).

### 1.3.7 Mechanical Specification

Front Panel Control	10-turn voltage and current potentiometers
Front Panel Voltage Control Resolution	0.02% of V max
Meter Accuracy	See Table 1.3-1 and Table 1.3-2.
AC Input Connector Type	3-terminal, 34A, 250V, right angle, PC mount, wire clamp connector with strain relief cover
Output	7.5V to 100V models: nickel-plated copper bus bars with bus bar cover and strain relief; bus bar holes: 0.343" (8.7 mm) D (1), 0.197" (5.0 mm) D (2); 150V to 600V models: 4-terminal, right angle, PC mount, wire clamp connector
Sense Connector	5-terminal wire clamp connector (2 piece)
Analog Programming Connector	15-terminal wire clamp connector (2 piece)
Chassis Ground	One chassis ground screw located on rear panel for bonding connections
Cooling	Fan cooled. Air exhausts to rear. Over temperature shutdown: automatic restart or latch off.
Mounting	Removable rack mount brackets. Mount at front panel or mid-chassis location.
Weight	Approximately 33 lbs. (15 kg)
Approvals	CE-marked units meet IEC 1010-1 safety standard and EN50081-2 and EN50082-1 EMC standards. Additional standards: CSA C22.2 No. 1010.1, UL 3101, and FCC, part 15, class A EMI standard.

1.3.7 Mechanical Specification (continued)

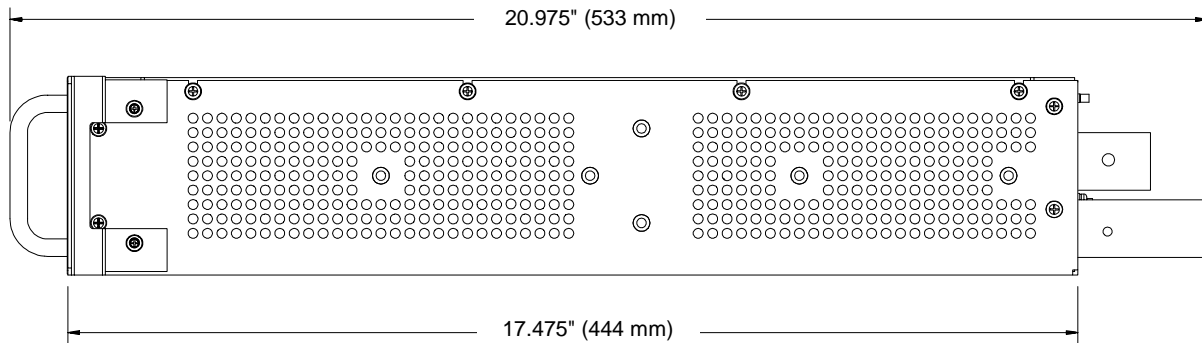
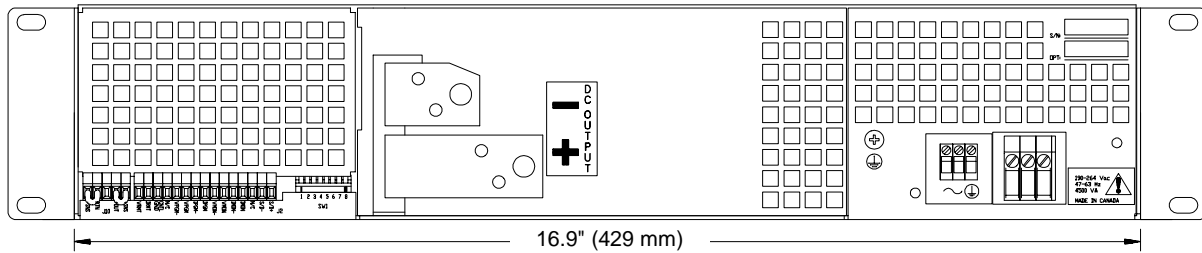
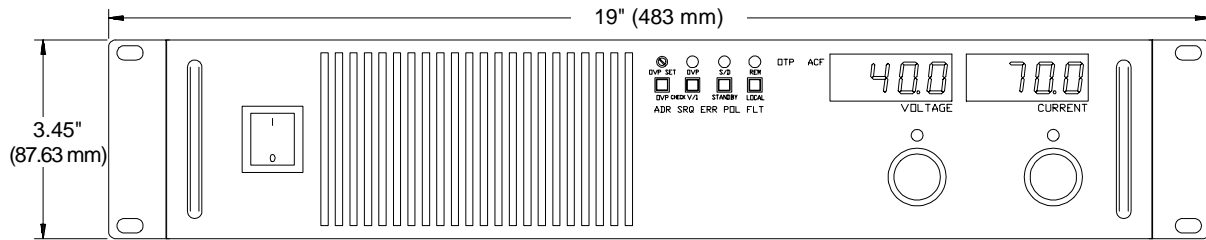

**Figure 1.3-2 Dimensional Drawings**  
 (Dimensions given are nominal.)

## 2. INSTALLATION

### 2.1 Introduction

This section provides recommendations and procedures for inspecting, installing, and testing the power supply. Refer to the front and rear panel diagrams, Figure 2.3-1 and Figure 2.3-2, as necessary.

### 2.2 Basic Setup Procedure

Table 2.2-1 provides both a summary of the basic setup procedure and an overall view of the subsections in Section 2. Use the procedure as a quick reference if you are familiar with the installation requirements for the power supply. If you want more information, each step in the procedure refers to subsequent sections which contain more details. Execute each step in the sequence given.

<b>Step #</b>	<b>Description</b>	<b>Action</b>	<b>Reference</b>
1	Inspection	Perform an initial physical inspection of the supply.	Section 2.3 Inspection, Cleaning, and Packaging
2	Installation	Install the supply (bench or rack mount), ensuring adequate ventilation.	Section 2.4 Location, Mounting, and Ventilation
3	Input Power	Connect AC input power.	Section 2.5 AC Input Power Connection
4	Test	Perform functional tests for voltage mode operation, current mode operation, and front panel controls.	Section 2.6 Functional Tests
5	Load	Connect the load.	Section 2.7 Load Connection
6	Sensing	Connect sensing lines.	Section 2.8 Local and Remote Sensing

See Section 3. Local Operation for instructions for front panel operation, over voltage and over temperature protection, shutdown, and using multiple supplies. You will find remote programming and monitoring described in Section 4. Remote Operation.

### 2.3 Inspection, Cleaning, and Packaging

#### 2.3.1 Initial Inspection

When you first receive your unit, perform a quick physical check.

1. Inspect the unit for scratches and cracks, and for broken switches, connectors, and displays. See Figure 2.3-1 and Figure 2.3-2.
2. Have the service technician check the printed circuit board and its components if you suspect internal damage.

If the unit is damaged, save all packing materials and notify the carrier immediately. See packing instructions in Section 2.3.3.



2.3.1 Initial Inspection (continued)

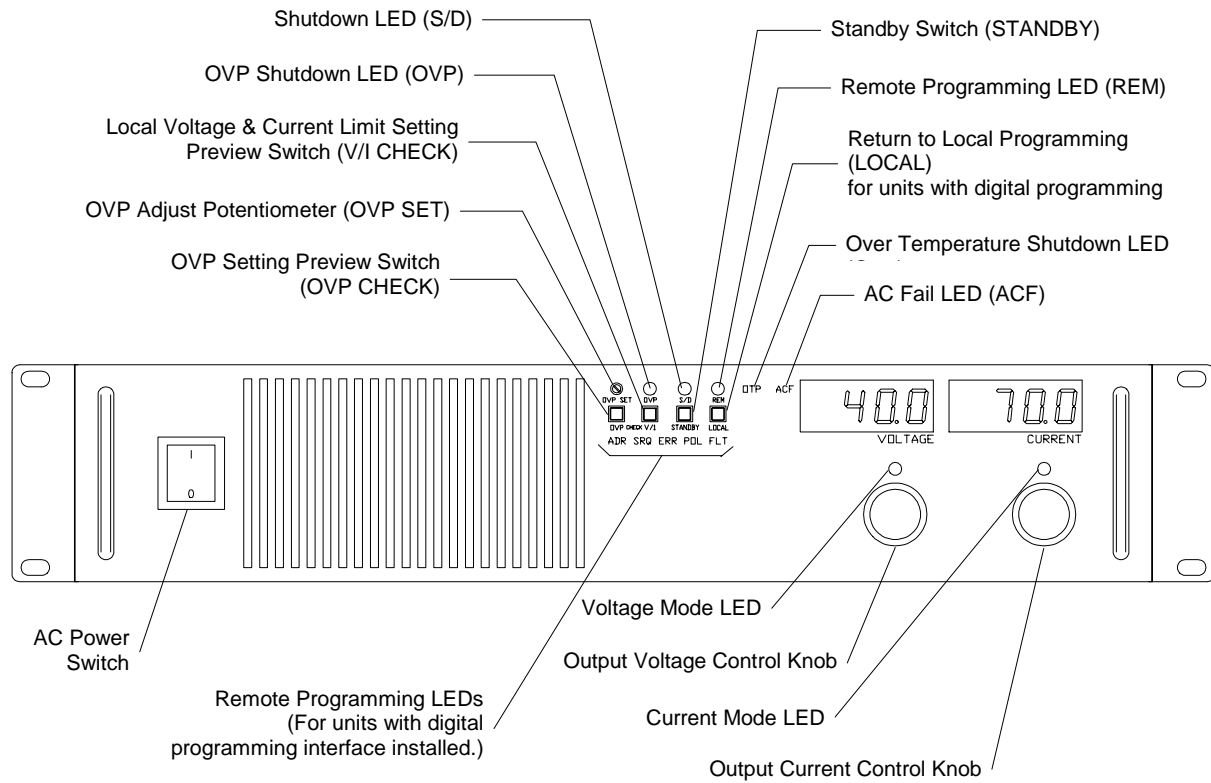
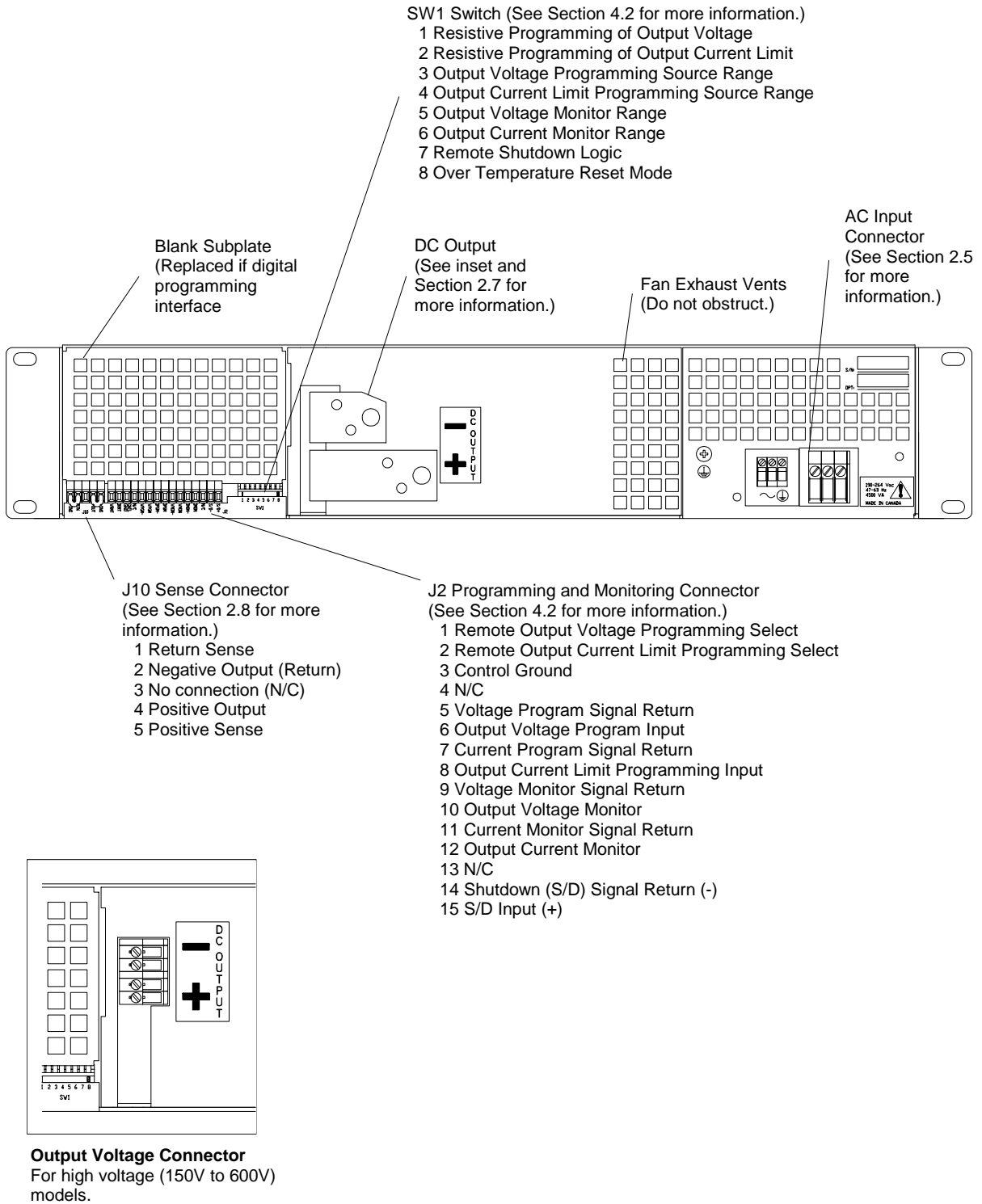

Figure 2.3-1 Power Supply Front Panel

2.3.1 Initial Inspection (continued)



**Figure 2.3-2 Power Supply Rear Panel**  
 (Bus bar output model (7.5V to 100V) shown.)

### 2.3.2 Periodic Cleaning

No routine servicing of the power supply is required except for periodic cleaning. Whenever a unit is removed from operation, clean metal surfaces with naphtha or an equivalent solvent and the front panel with a weak solution of soap and water. Use low-pressure compressed air to blow dust from in and around components on the printed circuit boards.

### 2.3.3 Packaging for Shipping or Storage

Follow these instructions to prepare the unit for shipping or storage.

1. When returning the unit or sending it to the service center, attach a tag to the unit stating its model number, available from the front panel label, and its serial number, available from the rear panel label. Give the date of purchase and an invoice number, if you have it, as well as a brief description of the problem.
2. For storage or shipping, repack the power supply in its original container. If the original container is not available, seal the unit in a plastic bag and then pack it in a 200 lb. (90 kg) test, corrugated cardboard carton large enough to allow 2" (5 cm) of cushioning material to surround the unit. Use a material such as foam slabs or chips.
3. Label the carton as shown in Figure 2.3-3.
4. If shipping, mark the address of the service center and your return address on the carton.
5. If storing, stack no more than eight cartons high. Check the storage temperature range and storage altitude specification in Section 1.3.6.

<b>POWER SUPPLY</b>	
Model Number:	_____
Serial Number:	_____
<b>FRAGILE - ELECTRONIC EQUIPMENT</b>	

**Figure 2.3-3 Shipping or Storage Carton Label**

## 2.4 Location, Mounting, and Ventilation

Use the power supply in rack mounted or in benchtop applications.

### 2.4.1 Rack Mounting

**WARNING**

Ensure that the screws for the rack mount brackets do not extend more than 1/8" (3.0 mm) into the sides of the unit.

The power supply is designed to fit in a standard 19" (483 mm) equipment rack. To install:

1. Use the rack mount brackets at either side of the front panel to install the power supply in a rack. To mount the supply for relay rack applications, remove the brackets from the location near the front panel and re-install them at their alternate locations which are midway along each side.
2. Provide adequate support for the rear of the unit without obstructing the ventilation inlets on the sides of the unit. Use a support bar such as Hammond RASB19WH2 at the rear of the unit. Follow the manufacturer's instructions to install the support bar.

To install the 2800 Watt power supply with rack mount slides, use a typical slide kit such as ZERO C-300 S-18. Follow the manufacturer's instructions to install the slides. Add a 1/8" (3.0 mm) spacer between the chassis and the slide.

### 2.4.2 Ventilation

Whether you place the power supply in a rack or on a bench, allow cooling air to reach the ventilation inlets on the sides of the unit and allow 4" (10 cm) of unrestricted air space at the rear of the unit for the fan exhaust. Any ventilation space at the top and bottom of the supply will further lower internal operating temperatures.

Check Section 1.3.6 for the operating ambient temperature range and the operating altitude specification.

## 2.5 AC Input Power



**WARNING**

There is a potential shock hazard if the power supply chassis and cover are not connected to an electrical ground via the safety ground in the AC input connector. Ensure that the power supply is connected to a grounded AC outlet with the recommended AC input connector configured for the available line voltage as set out in this section.

**WARNING**

Disconnect AC power from the unit before removing the cover. Even with the front panel power switch in the OFF position, live line voltages are exposed when the cover is removed. Repairs must be made by experienced service technicians only.

### 2.5.1 AC Input Connector and Voltage Selection

The AC input connector is a 3-terminal wire clamp connector located on the power supply's rear panel. See Figure 2.5-1 for a drawing of the connector. See Table 2.5-1 for the input voltage range and frequency required to operate the power supply.

Table 2.5-1 AC Input Voltage Range and Frequency	
AC Voltage Range	Frequency
190-264Vac 1 $\phi$ (24.3A maximum at 208Vac; 22.4A maximum at 230Vac)	47-63Hz

### AC Fail LED

The AC Fail (ACF) LED turns on when the input voltage is outside of the range specified for the power supply. The LED goes off when the input voltage is within the range.

### 2.5.2 AC Input Cord

The AC input cord we recommend is specified in Table 2.5-2. Add a plug suitable for use in the country in which you are operating. If you require a special cord, call us.

Table 2.5-2 AC Wire Specification		
Wire Size	Ratings	Cable Outside Diameter
3 x 12 AWG stranded copper	60°C minimum, 300V	0.800" maximum

**2.5.3 AC Input Wire Connection**

1. Strip outside insulation 4" (10 cm). Strip 0.55" (14 mm) at the end of each of the wires. Trim wires so that the ground wire is 0.5" (12 mm) longer than the other wires. See the inset in Figure 2.5-1 labeled Stripped AC Wire.
2. Undo the two screws for the AC wiring strain relief/cover on the rear panel. Remove the cover. See Figure 2.5-1
3. Loosen the strain relief screws. Insert the AC input cable through the strain relief until the outer cable jacket is flush with the inside of the strain relief. Tighten the strain relief cable clamp screw. See the inset in Figure 2.5-1 labeled AC Wire Installed in Strain Relief.
4. Route the AC wires to the input connector terminals as required. See Table 2.5-3. To connect the wiring, loosen the terminal screw, insert the stripped wire 0.55" (14 mm) into the terminal, and tighten the screw securely.
5. Reinstall the AC input cover, routing wires inside the cover to prevent pinching.

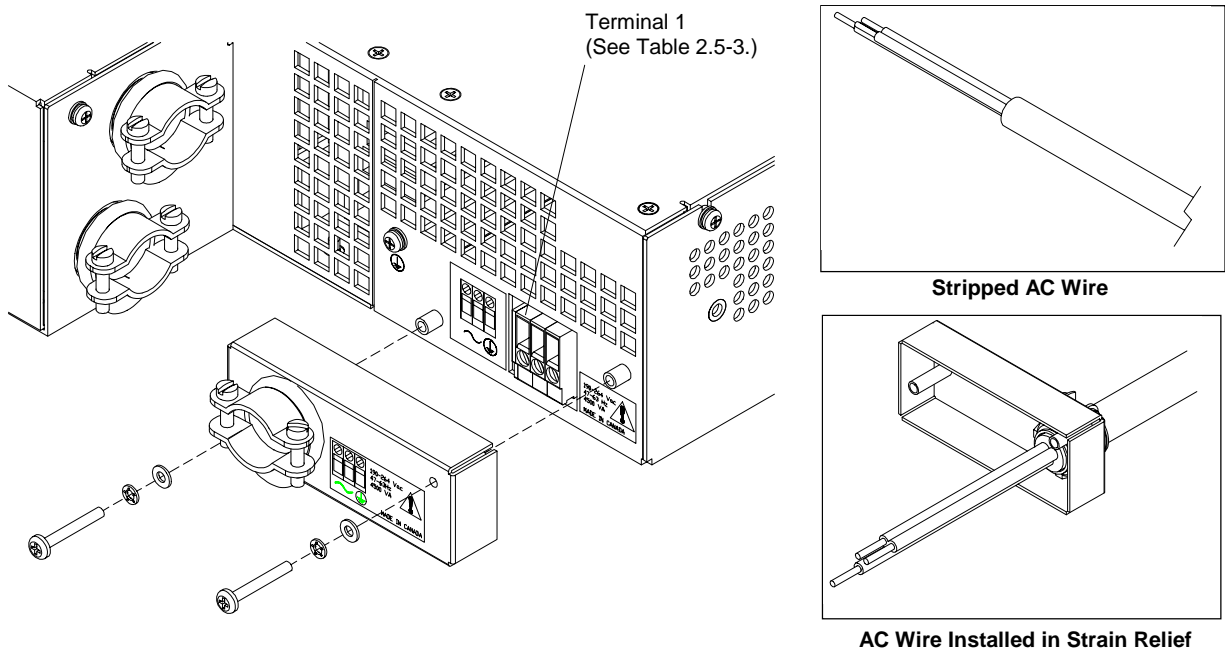

**Figure 2.5-1 AC Input Label and Strain Relief**

Table 2.5-3 AC Input Connector Terminals and Connections		
Terminal	Label	Connection
1	~	Line
2	~	Line
3	⊕	Safety Ground

## 2.6 Functional Tests

These functional test procedures include power-on and front panel function checks as well as voltage and current mode operation checks. Refer to front and rear panel diagrams in Section 2.3.

### 2.6.1 Equipment Required

- Digital voltmeter (DVM) rated better than 0.5% accuracy.
- DC shunt 1mV/A ( $\pm 0.25\%$ ) with connecting wire. The recommended current ratings for the DC shunt and the wire must be at least 10% more than the output current of the power supply.

### 2.6.2 Power-on Check

1. Ensure that the AC power switch is in the OFF position.
2. Ensure that the output sense lines are connected in the default configuration. (The local sense lines are connected between terminals 1 and 2 and between terminals 4 and 5 on the J10 sense connector as shown on the rear panel diagram in Figure 2.3-2.)
3. Turn the voltage and current controls fully counter-clockwise.
4. Connect the unit to an AC outlet.
5. Turn the front panel AC power switch to ON.

After a short, power-on delay, the front panel digital meters light up and the green voltage mode LED turns on. Both voltmeter and ammeter displays read zero.

### 2.6.3 Voltage Mode Operation Check

1. Ensure the voltage and current controls on the front panel are turned fully counter-clockwise.
2. Connect a DVM to the output terminals on the rear panel, observing correct polarity.
3. Turn the current control a 1/2-turn clockwise. Slowly turn the voltage control clockwise and observe both the front panel voltmeter and the DVM.
4. Compare the DVM reading with the front panel voltmeter reading to verify the accuracy of the internal voltmeter. Both readings should be the same. The minimum control range is from zero to the maximum rated output for the power supply model. The voltage mode LED turns on.
5. Turn the front panel AC power switch to OFF.

### 2.6.4 Current Mode Operation Check

1. Ensure the front panel AC power switch is set to OFF.
2. Turn the voltage and current controls on the front panel fully counter-clockwise.
3. Connect the DC shunt across the output terminals on the rear panel.
4. Connect the DVM across the DC shunt.
5. Turn the AC power switch to ON.
6. Turn the voltage control 1 or 2 turns clockwise.
7. Turn the current control slowly clockwise.
8. Compare the DVM reading with the front panel ammeter reading using  $I=V/R$  where I is the current, V is the DVM reading, and R is the DC shunt resistance. The minimum control range is from zero to the maximum rated output for the power supply model. The current mode LED turns on.
9. Turn the AC power switch to OFF.
10. Disconnect the DVM and the shunt.

### 2.6.5 Front Panel Function Checks

1. Turn the front panel AC switch to ON.
2. Set voltage and current controls fully clockwise. Push the STANDBY switch to its IN position and check that the voltmeter reading falls to zero and the red S/D (Shutdown) LED turns on. Push the STANDBY switch once again to reset it to its OUT position. The S/D LED turns off and the voltmeter reading returns to its previous value.
3. Press the STANDBY switch to its IN position.
4. Press the OVP CHECK switch and check that the voltmeter displays approximately the model-rated output voltage plus 10%.
5. Turn the OVP SET potentiometer counter-clockwise and check that the voltmeter reading decreases. Continued turning (up to 20 turns) will see the reading decrease to approximately 5% of the model-rated voltage output. Turn the OVP SET potentiometer clockwise until the voltmeter once again displays approximately the model-rated output voltage plus 10%.
6. Press the STANDBY switch to its OUT position.
7. Press the V/I CHECK switch and check that the voltmeter and ammeter display the power supply output ratings.
8. Turn the front panel AC power switch to OFF.

Note: You can use the front panel LOCAL button only when a digital programming interface has been installed in your power supply



## 2.7 Load Connection

This section provides recommendations for load wires and how to connect them for both single and multiple load configurations.

### 2.7.1 Load Wiring

When connecting load wiring to the power supply, consider the following factors:

- insulation rating of the wire
- current carrying capacity of the wire
- maximum load wiring length for operation with sense lines
- noise and impedance effects of the load lines

#### Insulation Rating



**WARNING**

There is a potential shock hazard at the output when using a power supply with a rated output greater than 40V. Use load wiring with a minimum insulation rating equivalent to the maximum output voltage of the power supply. For example, select TEW-105, 105°C, 600V wiring for use with a 600-4 model power supply.

#### Current Carrying Capacity

As a minimum, load wiring must have a current capacity greater than the output current rating of the power supply. This ensures that the wiring will not be damaged even if the load is shorted. Table 2.7-1 shows the maximum current rating, based on 450A per square centimeter, for various gauges of wire rated for 105°C operation. Operating at the maximum current rating results in an approximately 30°C temperature rise for a wire operating in free air. Where load wiring must operate in areas with elevated ambient temperatures or bundled with other wiring, use larger gauges or higher temperature-rated wiring.

<b>Table 2.7-1 Current Carrying Capacity for Load Wiring</b>			
<b>Wire Size (AWG)</b>	<b>Maximum Current (A)</b>	<b>Wire Size (AWG)</b>	<b>Maximum Current (A)</b>
20	2.5	6	61
18	4	4	97
16	6	2	155
14	10	1	192
12	16	1/0	247
10	21	2/0	303
8	36		

#### Load Wiring Length for Operation with Sense Lines

For applications using remote sensing, you must limit the voltage drop across each load. Figure 2.7-1 shows some maximum allowable wire lengths for a given load current and wire size. We recommend you use the larger load wiring to ensure a smaller voltage drop (1V typical maximum), although units will compensate for up to 5V drop in each line. See also Section 2.8 Local and Remote Sensing.

**2.7.1 Load Wiring (continued)**

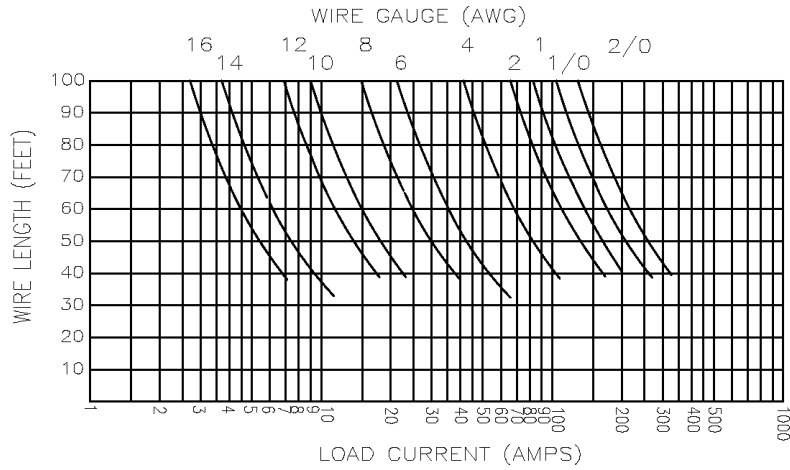

**Figure 2.7-1 Maximum Load Wire Length for 1V Line Drop**

**Noise and Impedance Effects**

To minimize noise pickup or radiation, use shielded-twisted pair wiring of the shortest possible length for load wires. Connect the shield to the chassis via a rear panel mounting screw. Where shielding is impossible or impractical, simply twisting the wires together will offer some noise immunity. When using local sense connections, use the largest practical wire size to minimize the effects of load line impedance on the regulation of the supply.

**2.7.2 Making Load Connections**



**WARNING**

There is a shock hazard at the load when using a power supply with a rated output greater than 40V. Install a physical shield for the connections at any load attached to a power supply with a rated output greater than 40V.

**CAUTION**

When making connections to the bus bars, ensure each terminal's mounting hardware and wiring assembly are placed to avoid touching the other terminal and shorting the power supply output. Heavy connecting cables must have some form of strain relief to avoid loosening the connections or bending the bus bars.

Make load connections at the rear of the power supply at the positive and negative output bus bars or to the 4-terminal wire clamp connector, depending on the model.

**2.7.2 Making Load Connections (continued)**

**7.5V to 100V Models**

The 7.5V to 100V models come with a bus bar cover and strain relief. See Figure 2.7-2.

To detach the bus bar cover before connecting load wires:

1. Undo #6-32 x 5/16" Phillips pan head screws, #6 x 0.288" lock washers, and #6 x 5/16" flat washers (3 places) from bus bar top cover.
2. Pull upward on output bus bar top cover to remove it.
3. Undo #6-32 x 1/4" Keps nuts and #6 x 5/16" flat washers from chassis-mounted PEM studs (3 places) to remove output bus bar chassis cover.

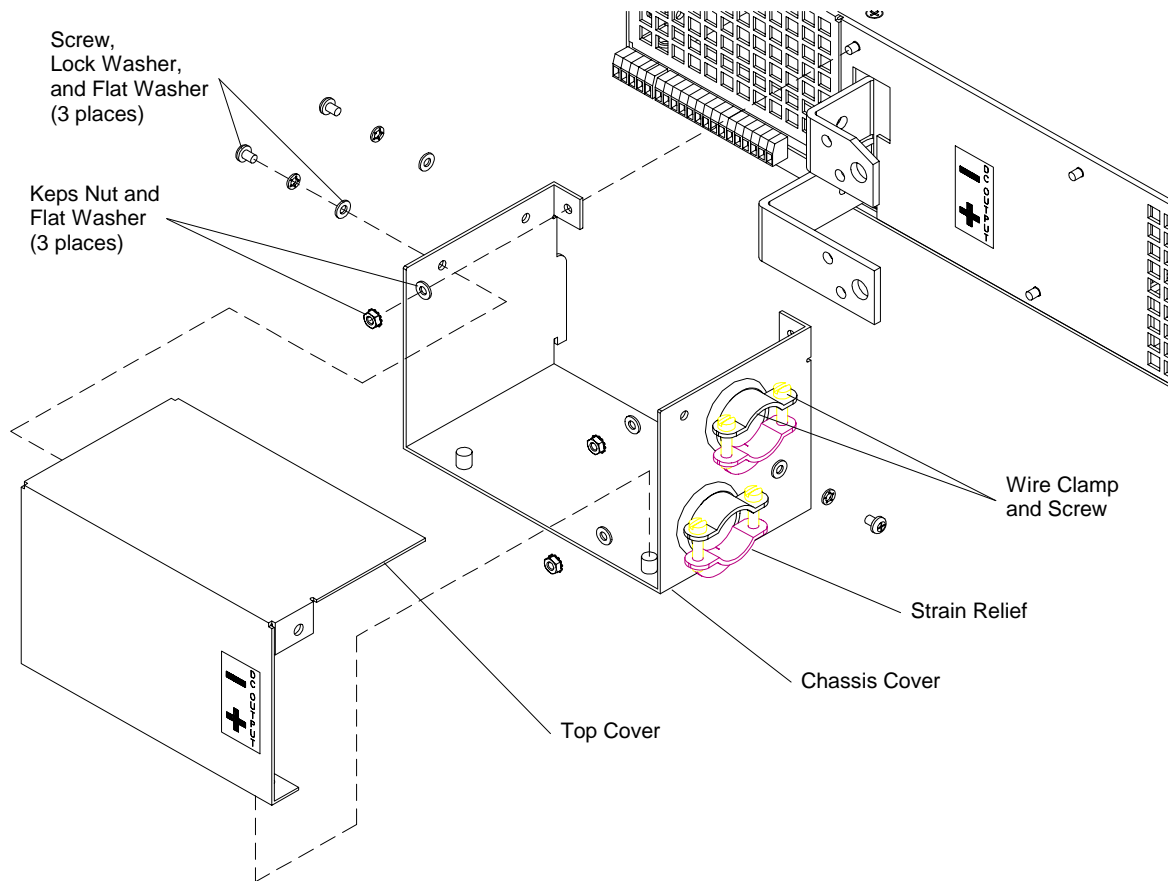

**Figure 2.7-2 Output Strain Relief and Bus Bar Cover**

### 2.7.2 Making Load Connections (continued)

To make load connections to a 7.5V, 300A power supply:

1. Remove bus bar top cover. Do not remove chassis-mounted part of the cover.
2. Loosen wire clamp screws (part of strain relief). Do not disassemble strain relief.
3. Insert load wire in strain relief.
4. Install connectors such as the Thomas and Betts wire connector #54158 to load wiring.
5. Fasten connectors to bus bars with 5/16" x 5/8" (M8 x 16 mm) screws, 5/16" (M8) flat washers, lock washers, and hex nuts as shown in Figure 2.7-3.

Note: Bus bar hole sizes are 0.343" D (1); 0.197" D (2).

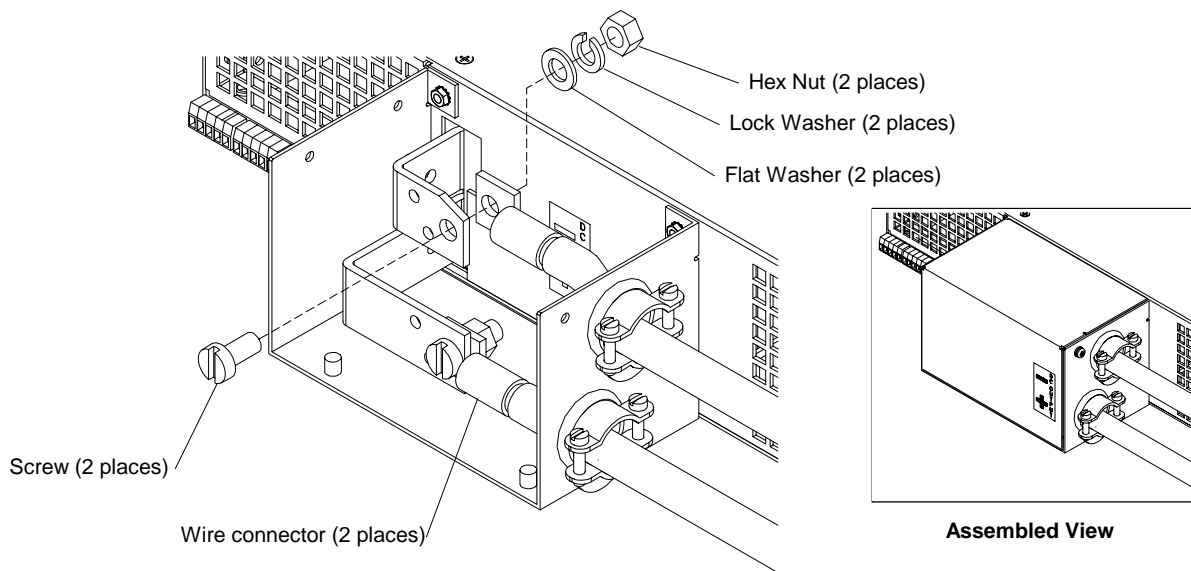

**Figure 2.7-3 Typical Load Connection Hardware**  
(Low voltage model shown.)

## 2.7.2 Making Load Connections (continued)

### 150V to 600V Models

**WARNING**

To protect personnel against accidental contact, install a physical shield for the connections at any load attached to a high voltage power supply.

The 150V to 600V models have a 4-terminal, wire clamp output connector. See Figure 2.7-4 for a labeled drawing of the wire clamp connector. To prepare and connect the load wiring:

1. Strip 0.4" (10 mm) at the end of each of the wires.
2. To connect the wiring, loosen each terminal screw, insert a stripped wire into the terminal, and tighten the screw securely.

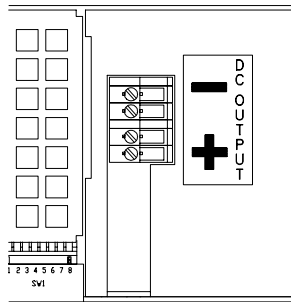

**Figure 2.7-4 Output Voltage Connector**  
(For high voltage (150V to 600V) models.)

## 2.7.3 Inductive Loads

To prevent damage to the power supply from inductive kickback, connect a diode across the output. The diode must be rated at greater than or equal to the supply's output voltage and have a current surge rating greater than or equal to the supply's output rating. Connect the cathode to the positive output and the anode to return.

Where positive load transients such as back EMF from a motor may occur, connect a transorb or a varistor across the output to protect the power supply. The breakdown voltage rating for the transorb or varistor must be approximately 10% higher than the rated supply output.

**2.7.4 Connecting Single Loads**

Figure 2.7-5 and Figure 2.7-6 show recommended load and sensing connections for single loads. Local sense lines shown are default connections at the rear panel J10 sense connector as identified on Figure 2.3-2.

You do not need remote sensing for basic operation of your supply. However, if you wish to correct any small drops in your load lines, then use the remote sensing feature. See Section 2.8 Local and Remote Sensing for more information.

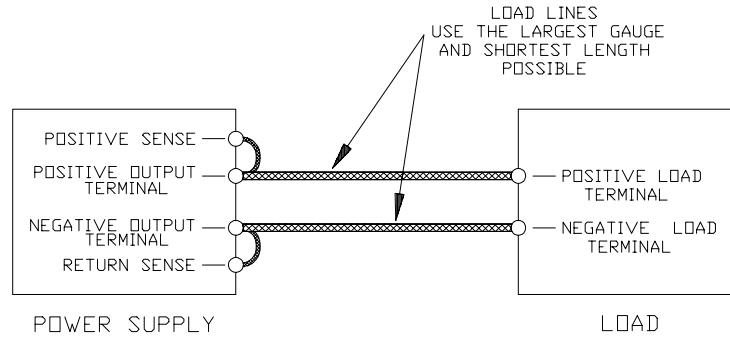

**Figure 2.7-5 Single Load with Local Sensing (Default)**

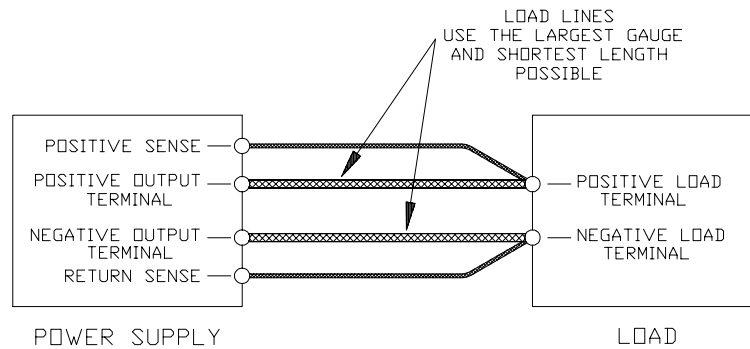

**Figure 2.7-6 Single Load with Remote Sensing**

**2.7.5 Connecting Multiple Loads**

Proper connection of distributed loads is an important aspect of power supply use. Two common methods of connection are the parallel power distribution method and the radial power distribution method.

**Parallel Power Distribution**

This distribution method involves connecting leads from the power supply to one load, from that load to the next load, and so on for each load in the system. This method results in the voltage at each load depending on the current drawn by the other loads and allows DC ground loops to develop. Except for low current applications, we do not recommend using this method.

**2.7.5 Connecting Multiple Loads (continued)**

**Radial Power Distribution Method**

To connect distributed loads, we recommend that you use radial power distribution. With this method, you connect power to each load individually from a single pair of terminals designated as the positive and negative distribution terminals. These terminals may be the power supply output terminals, the terminals of one of the loads, or a distinct set of terminals especially established for distribution use. Connect the sense leads to these terminals to compensate for losses and minimize the effect of one load upon another.

Figure 2.7-7 and Figure 2.7-8 show recommended load and sensing connections for multiple loads. Local sense lines shown are default J10 sense connections. See Section 2.8 Local and Remote Sensing for more information about using remote sensing and grounding the sense line shield.

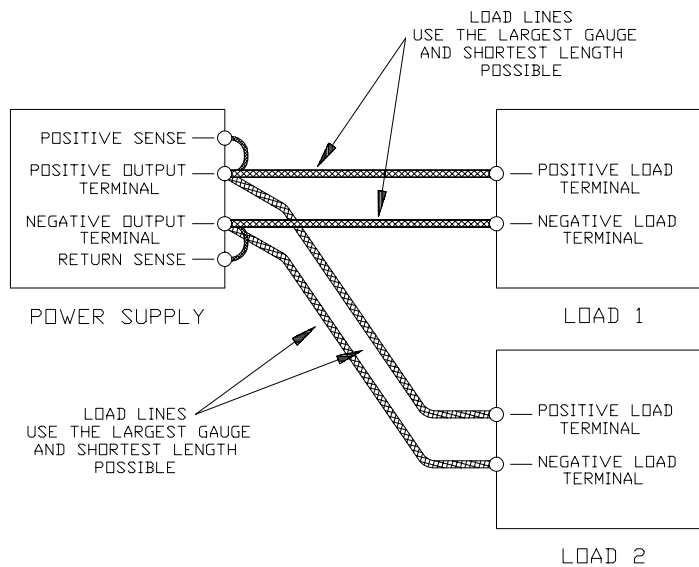

**Figure 2.7-7 Multiple Loads with Local Sensing**

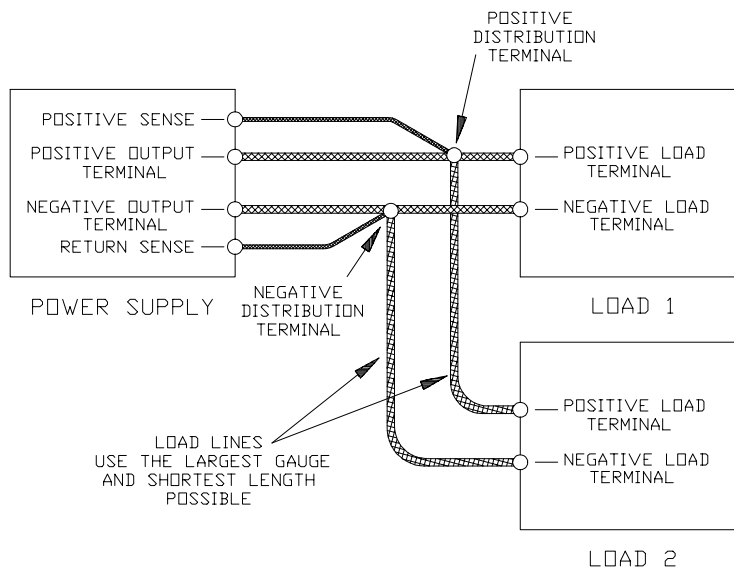

**Figure 2.7-8 Multiple Loads with Remote Sensing**

## 2.8 Local and Remote Sensing

Use connections at the rear panel J10 sense connector to configure the power supply for local or remote sensing of output voltage. See Figure 2.8-1 for a drawing of the sense connector.

### 2.8.1 Sense Wiring

 **WARNING**

There is a potential shock hazard at the sense connector when using a power supply with a rated output greater than 40V. Select wiring with a minimum insulation rating equivalent to the maximum output voltage of the power supply for use as local sense jumpers or for remote sense wires. For example, select TEW-105, 105°C, 600V wiring for use with a model 600-4 power supply.

For lowest noise performance, use shielded-twisted pair wiring of 16 to 24 AWG for remote sense lines. Strip wires 0.26" (6.5 mm) and insert securely as with any wire clamp connector.

### 2.8.2 Local Sensing

We ship the power supply with the rear panel J10 sense connector jumpered for local sensing of the output voltage. See Table 2.8-1 for the list of connector functions and a description of local sense connections. With local sensing, the output voltage is regulated at the output terminals (or bus bars). This method does not compensate for voltage losses in the load lines, so it is recommended only for low current applications or applications for which load regulation is not essential.

Note: When using local sense connections, use the largest practical load wire size to minimize the effects of line impedance on the regulation of the supply.

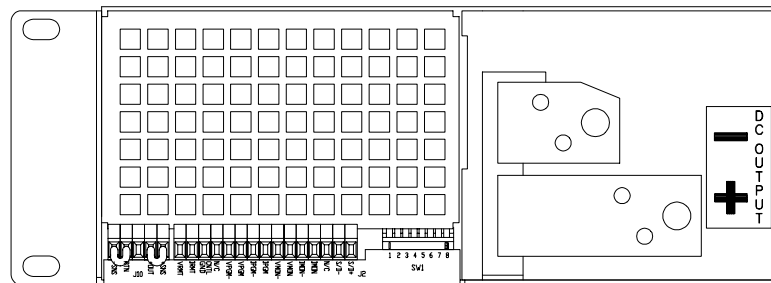

**Figure 2.8-1 J10 Sense Connector**  
(Shown with local sense jumpers connected.)

Table 2.8-1 Rear Panel J10 Sense Connector Terminals and Functions		
Terminal	Name	Function
J10-1	Return Sense (-SNS)	Remote negative sense connection. Default connection to terminal 2.
J10-2	Negative Output ( Return or RTN)	Connected internally to negative bus bar.
J10-3	N/C	No connection.
J10-4	Positive Output (+OUT)	Connected internally to positive bus bar.
J10-5	Positive Sense (+SNS)	Remote positive sense connection. Default connection to terminal 4.



### 2.8.3 Using Remote Sensing

**WARNING**

There is a potential shock hazard at the sense points when using a power supply with a rated output greater than 40V. Install a physical shield for the sense connections at the load or at any other sense point chosen when using a power supply with a rated output greater than 40V.

**CAUTION**

Ground the sense line shield in one place only. Locations include: the power supply's return output connection at the load, the power supply's return output at its negative output terminal, or the power supply's chassis.

**CAUTION**

Do not use remote sensing with multiple supplies connected in series.

Use remote sensing during voltage mode operation to shift the power supply's regulation point from its default position at the rear panel output terminals to the load or distribution terminals by using a separate pair of wires to allow the control circuitry to monitor the load voltage. This allows the power supply to compensate for voltage losses in the load lines which will otherwise degrade the regulation of the supply. Line drop is subtracted from the voltage available at the power supply's output.

To connect remote sense lines:

1. Turn OFF the power supply.
2. Remove the local sense jumpers connecting J10 mating connector terminal 5 (positive sense) to terminal 4 (positive output) and terminal 1 (return sense) to terminal 2 (power supply return).
3. Connect the positive remote sense lead to J10 mating connector terminal 5 (positive sense) and the negative lead to terminal 1 (return sense). Ensure the mating connector is plugged securely into the rear panel sense connector. Connect the other ends of the sense wires to the corresponding sense points at the load.
4. To prevent ground loops, ground the sense line shield, at one point only, to the power supply's return output connection at the load, to the power supply's return output at its negative output terminal, or to the power supply's chassis.
5. Turn the power supply ON.

Notes:

1. If you operate the power supply with remote sense lines connected to the load and with either of the positive or negative load lines **not** connected, the power supply shutdown circuit will activate, causing the output voltage and current to fall to zero.
2. If you operate the power supply **without** remote sense lines **or** local sense jumpers in place, the supply will continue to work, but supply regulation will be degraded and/or erratic, or, the OVP circuit may activate.

Figure 2.8-2 shows a sample setup for using remote sensing.

2.8.3 Using Remote Sensing (continued)

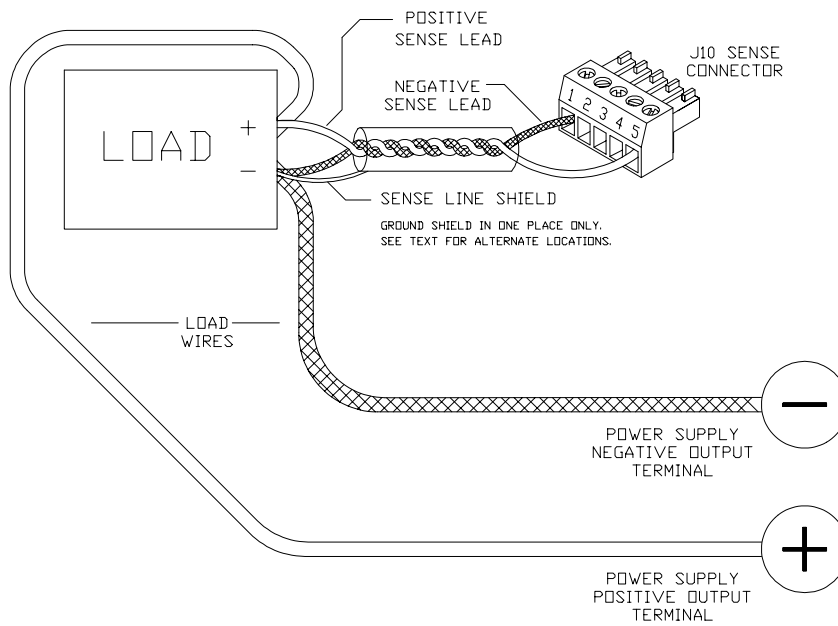

Figure 2.8-2 Connecting Remote Sense Lines

### 3. LOCAL OPERATION

#### 3.1 Introduction

Once you have installed the power supply and have connected both the AC input power and the load as covered in Section 2. Installation, the power supply is ready to operate in local control mode (that is, operation at the unit's front panel).

Section 3.2 Standard Operation offers a brief explanation of Constant Voltage and Constant Current Mode operation. Sections 3.3 to 3.6 cover power supply functions such as over voltage protection, shutdown function, over temperature protection, and using multiple supplies. Section 3.7 provides troubleshooting information for the operator.

For descriptions of remote programming options and remote monitoring of the power supply, turn to Section 4. Remote Operation.

#### 3.2 Standard Operation

This power supply has two basic operating modes: Constant Voltage Mode and Constant Current Mode, and two control modes: Local Control Mode (default setting) and Remote Programming Mode. Both operating modes are available regardless of which control mode is used.

##### 3.2.1 Operating Modes and Automatic Crossover

Whether controlled by local or remote programming, the power supply has two basic operating modes: Constant Voltage Mode and Constant Current Mode. The mode in which the power supply operates at any given time depends on the combination of:

- output voltage setting  $V_{SET}$
- output current limit setting  $I_{SET}$
- resistance of the attached load  $R_L$

Figure 3.2-1 Operating Modes provides a graphical representation of the relationships between these variables.

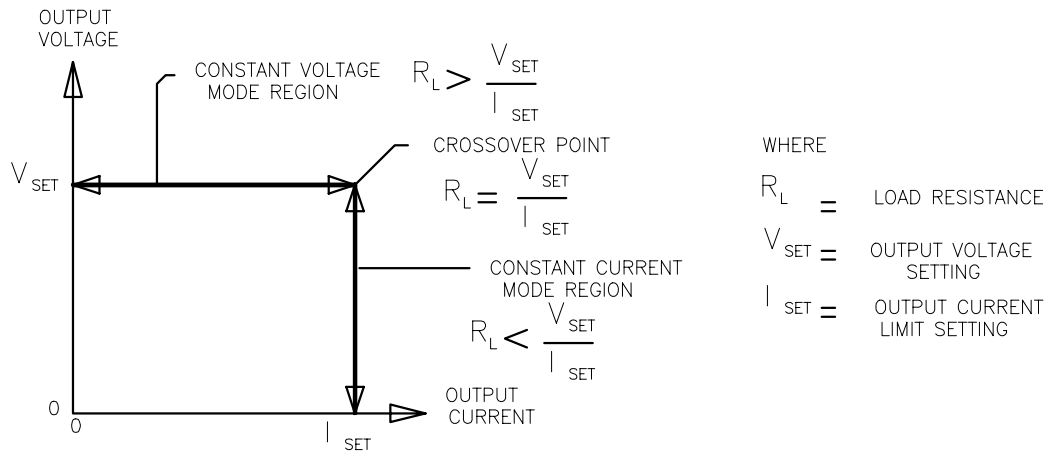

Figure 3.2-1 Operating Modes

**3.2.1 Operating Modes and Automatic Crossover (continued)**

**Constant Voltage Mode Operation**

The power supply will operate in constant voltage mode whenever the load current  $I_L$  is **less than** the current limit setting  $I_{SET}$ , or:  $I_L < I_{SET}$  (Note:  $I_L = V_{SET} / R_L$ )

In constant voltage mode, the power supply maintains the output voltage at the selected value ( $V_{SET}$ ) while the load current  $I_L$  varies with the load requirements.

**Constant Current Mode Operation**

The power supply will operate in constant current mode whenever the load resistance is low enough that the load current  $I_L$  is **equal to** the current limit setting  $I_{SET}$  (Note:  $V_L = I_{SET} R_L$ )

In constant current mode, the power supply maintains the output current at the selected value ( $I_{SET}$ ) while the load voltage varies with the load requirements.

**Automatic Mode Crossover**

This feature allows the power supply to automatically switch operating modes in response to changing load requirements. If, for instance, the power supply was operating in Constant Voltage Mode ( $I_L < I_{SET}$ ), and the load changed so that the load current ( $I_L$ ) became **equal to** the current limit setting ( $I_{SET}$ ), the power supply would automatically switch into Constant Current Mode and the output voltage would vary in response to changes in load current. If the additional load was subsequently removed so that the load current was again **less than** the current limit setting, the supply would automatically return to Constant Voltage Mode.

**3.2.2 Shipped Configuration (Local Control Mode)**

The factory ships units already configured for local control (front panel) operation. Table 3.2-1 summarizes this configuration. See Figure 2.3-1 and Figure 2.3-2 for front and rear panel diagrams.

<b>Table 3.2-1 Shipped Configuration (Local Control Mode)</b>	
<b>Local Control Configuration</b>	<b>Additional References</b>
Use the front panel controls to adjust the output voltage and current limit settings. (Note: Use the LOCAL button only when you have a digital programming interface installed.)	Section 3 covers front panel operation. See Section 4 Remote Operation for remote analog programming procedure(s).
The supply's sense point is at the rear panel J10 sense connector terminals.	See Section 2.8 Local and Remote Sensing for how to change from local to remote sensing.
The over voltage protection (OVP) set point is adjusted at the front panel to approximately 110% of rated output voltage.	See Section 3.3 Using Over Voltage Protection (OVP) for the adjustment procedure.
The over temperature shutdown function automatically resets when activated as determined by the position of rear panel switch SW1-8. A latch off setting is also available.	See Section 3.6 Over Temperature Protection (OTP) for more information about switch SW1-8 settings.

### 3.2.3 Setting Output Voltage and Current Limit

Install the power supply and connect the load as described in Section 2. Installation. Ensure the power supply is set up for local control as described in Section 3.2.2. Then, set the output voltage and current limit at the front panel with the following procedure.

1. Turn both the voltage and current controls fully counter-clockwise.
2. Turn the AC power ON.
3. Press the STANDBY switch to its IN position to disable the power supply output. The red Shutdown (S/D) LED turns on.
4. Press and hold the V/I CHECK button to display the voltage and current control settings on the voltmeter and ammeter displays.
5. Adjust the voltage control to the desired voltage (the compliance voltage for applications using current mode operation).
6. Adjust the current control to the desired current limit setting.
7. Release the V/I CHECK button.
8. Press the STANDBY switch to its OUT position to apply power to the load. The S/D LED turns off.

### 3.3 Using Over Voltage Protection (OVP)

The OVP circuit protects the load in the event of a remote programming error, an incorrect voltage control adjustment, or a power supply failure. The protection circuit monitors the output voltage at the output of the power supply and will shut down the main power converter whenever a preset voltage limit is exceeded. Set the preset voltage limit (also called the set point or trip level) using the screwdriver-adjustable, front panel OVP potentiometer, or via one of the optional GPIB or RS-232 programming interfaces.

Notes:

1. The default preset limit is approximately 110% of the rated output voltage.
2. When using OVP with remote sensing lines connected, compensate for the voltage line drop across the output return line by measuring or calculating the line drop, then adding this value to the desired OVP setpoint.

#### 3.3.1 Front Panel OVP Operation

In local control mode, check the OVP set point at any time by pressing the OVP CHECK switch. The OVP set point is the value displayed on the digital voltmeter.

To set the trip level from the front panel:

1. Disconnect any loads. Turn the power supply ON.
2. Adjust the power supply output voltage to any voltage lower than the desired trip level.
3. Press the front panel STANDBY (output shutdown) switch to its IN position. The red S/D LED turns on.
4. Press the OVP CHECK switch to see the OVP set point on the voltmeter display.
5. Holding down the OVP CHECK switch, turn the OVP SET potentiometer until the desired set point is reached. Release the OVP CHECK switch.
6. Press the STANDBY switch to its OUT position. The S/D LED turns off.
7. To check that the power supply shuts off at the desired set point, slowly increase the output voltage while monitoring the front panel voltmeter. The OVP LED on the front panel turns on when the OVP circuit activates.

#### 3.3.2 Resetting the OVP Circuit

To reset the OVP circuit after it activates:

1. Reduce the power supply's output voltage setting to below the OVP set point.
2. Press the STANDBY switch IN. The red S/D LED on the front panel turns on. The OVP LED turns off.
3. Press the STANDBY switch again to return power to the load and resume normal operation.

OR

1. Reduce the power supply's output voltage setting to below the OVP set point.
2. Turn the power supply OFF using the AC power switch, wait until the front panel displays go out, then turn the power supply back ON again.

## 3.4 Using the Shutdown Function

Use the Shutdown function to disable or enable the supply's output so that you can make adjustments to either the load or the power supply without shutting off the power supply. Activate this function from the front panel at any time by using the STANDBY switch. You can also activate it via remote control through the rear panel J2 Programming and Monitoring connector, using a 2.5 to 15V signal or a transistor-transistor logic (TTL) compatible signal. The input lines for the Shutdown circuit are optically isolated.

### 3.4.1 STANDBY Switch

The STANDBY switch is a press ON/press OFF switch located on the power supply's front panel. See the front panel diagram in Section 2.3. Push the switch to its IN position to activate the Shutdown circuit. The output voltage and current to fall to zero and the red S/D (Shutdown) LED turns on. Push the switch once more to reset it to its OUT position and resume normal power supply operation.

### 3.4.2 Controlling the Shutdown Function via the J2 Connector

The shutdown circuit accepts a 2.5 to 15V signal to disable or enable the power supply output. Make connections for signals at connector J2, located on the unit's rear panel. Set rear panel switch SW1-7 to select signal logic. See Section 4.2 for more information about making J2 connector and SW1 switch changes.

To activate the shutdown function:

1. Turn OFF the power supply.
2. Connect the signal source to J2 connector terminal 15 (Shutdown Input/positive) and terminal 14 (Shutdown Return).
3. Set switch SW1-7 to select the desired circuit logic as set out in Table 3.4-1.
4. Turn on the power supply. The power supply will operate as described in the "**Supply Output**" column in Table 3.4-1, according to the logic you select and the level of the input signal. The S/D (Shutdown) LED on the front panel turns on when the Shutdown circuit is activated.

Switch SW1-7 Setting	Source Signal	Signal Level	Supply Output	S/D LED
OFF (Active low, default)	2-15V	HIGH	OFF	ON
	0-0.4V	LOW	ON	OFF
ON (Active high)	2-15V	HIGH	ON	OFF
	0-0.4V	LOW	OFF	ON

Notes:

1. If switch SW1-7 is ON but there is no signal applied, the S/D LED turns on and the power supply will not provide an output until the HIGH signal level is applied.
2. The rear panel SW1 switch is marked with the word OPEN on its upper surface. Any of the eight switches on SW1 is OFF when it has been flipped up to break contact, ON when flipped down to close contact.

### 3.5 Using Multiple Supplies

**CAUTION**

Do not connect power supplies from different manufacturers in parallel or in series.

**CAUTION**

The remote programming inputs are internally referenced to the supply's negative output. Do not connect remote programming ground lines (J2 terminals 3, 5, and 7) to the supply's positive output.

You can operate power supplies of the SAME MODEL with outputs in series or in parallel to obtain increased load voltage or increased current. Split supply operation gives you two positive outputs or a positive and a negative output.

Note: If your application requires the use of isolated programming inputs, contact the manufacturer about the optional ISOL Interface.

#### 3.5.1 Configuring Multiple Supplies for Series Operation

**CAUTION**

Do not use remote sensing during series operation.

**CAUTION**

The maximum allowable sum of the output voltages is 600Vdc.

Use series operation to obtain a single higher voltage output using two or more supplies. Connect the negative (-) output terminal of one supply to the positive(+) output terminal of the next supply. See Figure 3.5-1. The total voltage available is the sum of the maximum voltages of each supply (add voltmeter readings). The maximum allowable current for a series string of power supplies is the output current of a single supply in the string.

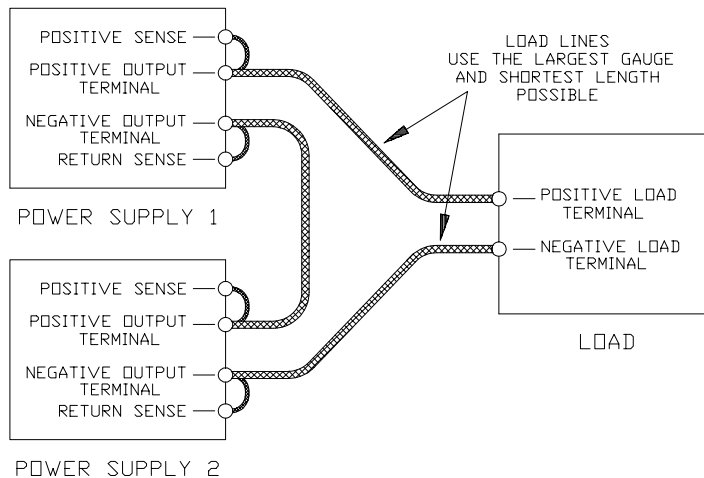

**Figure 3.5-1 Series Operation of Multiple Supplies**  
(Local sense lines shown are default J10 connections.)



### 3.5.2 Configuring Multiple Supplies for Parallel Operation

Use parallel operation to obtain a higher current through a single output using two or more supplies. Set all of the OVP setpoints to maximum. (See Section 3.3 Using Over Voltage Protection.) Set all of the outputs to the same voltage before connecting the positive (+) output terminals and negative (-) output terminals in parallel. See Figure 3.5-2. The total current available is the sum of the maximum currents of each supply.

When operating multiple supplies in parallel, the operating mode of each supply depends on the load current being drawn. For example, with two 40V-70A power supplies operating in parallel with a 100A load, one supply operates in constant current mode supplying 70A and the other supply operates in voltage mode supplying the remaining 30A. The level of current sharing between units depends on how accurately the output voltages are matched.

Note: If you do not fix the OVP setpoints at maximum, the OVP circuit may trip on one unit, reducing the current available to the load.

#### Sensing for Parallel Operation

Use default local sensing to enhance power sharing between units, as the impedance of the load lines will tend to correct for current imbalance. If you use remote sensing at the load for better voltage regulation, one supply always operates in current limit mode and supplies most of the power.

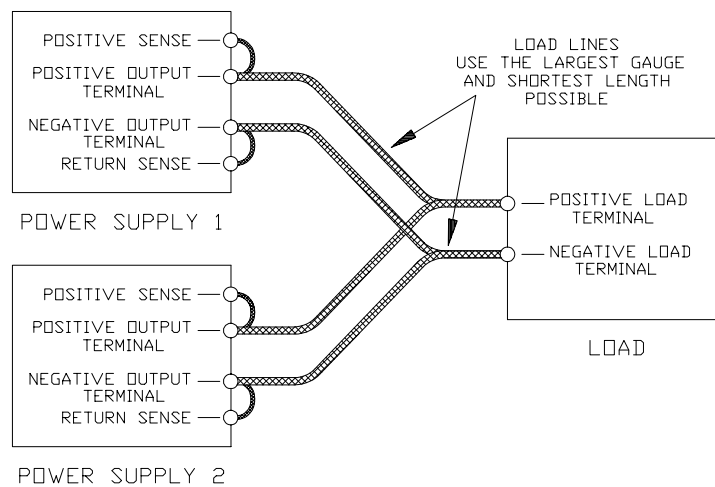

**Figure 3.5-2 Parallel Operation of Multiple Supplies**  
(Local sense lines shown are default J10 connections.)

### 3.5.3 Configuring Multiple Supplies for Split Supply Operation

Split supply operation uses two power supplies to obtain two positive voltages with a common ground, or to obtain a positive-negative supply.

#### Two Positive Voltages

To obtain two positive voltages, connect the negative output terminals of both supplies together in a common connection. The positive output terminals will provide the required voltages with respect to the common connection. See Figure 3.5-3.

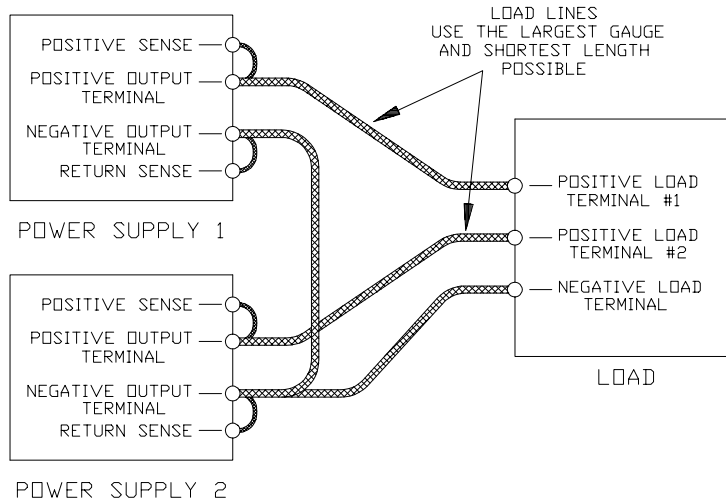

**Figure 3.5-3 Split Supply Operation of Multiple Supplies (Two Positive Voltages)**  
 (Local sense lines shown are default J10 connections.)

### 3.5.3 Configuring Multiple Supplies for Split Supply Operation (continued)

#### Positive-negative Supply

**CAUTION**

To prevent possible damage to the supply, do not connect the remote program return line of the negative supply to the common connection.

To obtain a positive-negative supply, connect the negative output terminal of one supply to the positive output terminal of the second supply. The positive output terminal of the first supply then provides a positive voltage relative to the common connection while the negative output terminal of the second supply provides a negative voltage. You can set the current limits independently. The maximum current available in split supply operation is equal to the rated output of the supplies. For example, 70A for two 40V-70A models. See Figure 3.5-4.

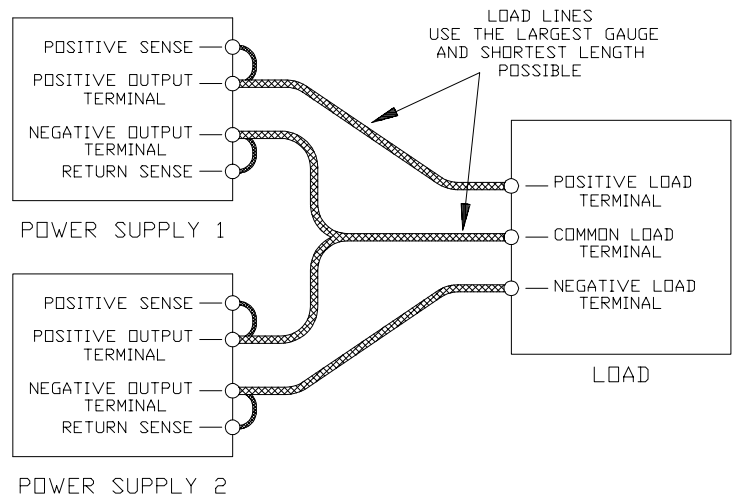

**Figure 3.5-4 Split Supply Operation of Multiple Supplies (Positive-negative Supply)**  
(Local sense lines shown are default J10 connections.)

## 3.6 Over Temperature Protection (OTP)

The OTP function allows you to select how the power supply recovers from an over temperature shutdown using the rear panel switch SW1-8. Table 3.6-1 shows the switch settings and selections. See Section 4.2 for more information about the switch. The OTP shutdown circuit activates before the internal components can exceed their safe internal operating temperatures. When an OTP shutdown occurs, the front panel OTP LED turns on.

Table 3.6-1 Switch Settings for Over Temperature Recovery Options		
Switch SW1-8	OTP Shutdown Selection	Description
OFF (OPEN)	Auto Reset (Default)	The supply recovers to normal operation when the over temperature condition no longer exists.
ON (CLOSED)	Latch OFF	After an over temperature shutdown, the supply stays OFF until you turn the AC power switch OFF, then you turn the power supply ON to continue use.

## 3.7 User Diagnostics

If your power supply is not performing as described in this operating manual, run through the procedures and checks in this section before calling your service technician. These procedures are confined to operator-level functions only and do not require cover-off servicing.

### 3.7.1 Emergency Shutdown

In an emergency, carry out both of these steps:

1. Shut the power supply off immediately.
2. Disconnect the power supply from the load.

### 3.7.2 Unusual or Erratic Operation

If the power supply displays any unusual or erratic operation, follow these steps:

1. Shut the power supply off immediately.
2. Disconnect the power supply from the load.
3. Test the power supply with no load, running the tests in Section 2.6 Functional Tests.
4. If the tests show that the power supply is functioning normally, check all load, programming, and monitoring connections and circuits.
5. Check the AC input for correct voltage and frequency.

If the problem is not solved after following this procedure, or if the unit fails to operate correctly upon retesting, call your service technician.

Turn to the next page for more information about troubleshooting for operators.

### 3.7.3 Troubleshooting for Operators

Use the checks in Table 3.7-1 to ensure that the power supply is configured and connected for normal operation.

#### Abbreviated References Used in Table

ACF	AC fail
OTP	over temperature protection
OVP	over voltage protection
PCB	printed circuit board
PFC	power factor correction
REM	remote mode
S/D	shutdown
V	volts

Table 3.7-1 User Diagnostics		
Symptom	Check	Further Checks and Corrections
No output and the display is blank.	Is input voltage within specified range?	Connect to appropriate voltage source. See Section 2.5.
	Power switch ON?	Turn on power.
	Internal circuit?	See your service technician.
No output but the display turns on.	OVP LED turned on?	See Section 3.3.
	Front panel S/D LED turned on?	See Section 3.4.
	OTP LED turned on?	See Section 3.6.
	Current limit set to zero?	See Section 3.2.
	Voltage control set to zero?	See Section 3.2.
	REM LED turned on?	If using remote analog control, check your analog programming source (Section 4). If not, refer to your digital interface manual.
	Is front panel ACF LED turned on?	Connect unit to AC supply in specified range. See Section 2.5.
Output not adjustable.	Internal circuit.	See your service technician.
	Is unit in current limit mode? (Red Current Mode LED turned on.)	Turn current knob clockwise to increase current limit. Reduce load if current is at maximum. See Section 3.2.
	Is unit in remote mode? (Green REM LED turned on.)	If using remote analog control, check your analog programming source (Section 4). If not, refer to your digital interface manual.
Output voltage fluctuating or regulation poor.	Is unit at maximum voltage or current limit?	Reduce load for lower voltage or current requirement.
	Is unit at current limit?	Increase current limit setting or reduce load. See Section 3.2.
	Is input voltage within specified range?	Connect to appropriate AC voltage source. See Section 2.5.
	Are sense lines connected?	See Section 2.7 Load Connection and Section 2.8 Local and Remote Sensing.
	Is unit under remote analog control?	Ensure program source is stable.
Output oscillating.	Internal circuit.	See your service technician.
	Internal circuit.	See your service technician.

## 4. REMOTE OPERATION

### 4.1 Introduction

The rear panel switches and connector on the power supply allow you to program the supply with an analog device or to output readback signals. This section covers the following topics.

- Section 4.2 explains how to use the programming and monitoring selection switch and connector.
- Section 4.3 contains procedures for remote analog programming of output voltage and current limit with 0-5V and 0-10V voltage sources and 0-5k $\Omega$  and 0-10k $\Omega$  resistances.
- Section 4.4 shows the connector and switch settings for using calibrated readback signals for output voltage and output current with selectable 0-5V or 0-10V scales.

**Isolated Programming.** The four-channel Isolated (ISOL) Programming Interface is an internal card which is ordered as an option. It allows remote programming and readback of the power supply's output voltage and current limit with 0-5V analog signals at a different potential relative to the power supply's output. The ISOL Interface is described in Section 4.5.

**Remote Digital Programming.** You can operate the power supply from a computer if you have had the GPIB or RS-232 Interface card installed as an option. Refer to the separate interface manual for all setup and operation instructions for remote digital programming.

### 4.2 Switches and Connector Used for Remote Programming and Monitoring

Use the rear panel SW1 Programming, Monitoring, and Shutdown Select switch and the rear panel J2 Programming and Monitoring connector to choose among several remote programming and monitoring options. This section lists the functions of each of the switches and the connector terminals and provides you with the procedures for resetting them.

#### 4.2.1 Rear Panel SW1 Switch

The SW1 Programming, Monitoring, and Shutdown Select switch is an 8-position piano DIP switch located on the power supply's rear panel. See Figure 4.2-1. The SW1 switch enables you to choose:

- Resistive programming of output voltage or current limit
- Output voltage and current limit programming scales
- Output voltage and current monitor scales
- Remote shutdown circuit logic
- Over temperature shutdown mode

- 1 Resistive Programming of Output Voltage
- 2 Resistive Programming of Output Current
- 3 Selects Output Voltage Programming Source Range
- 4 Selects Output Current Limit Programming Source Range
- 5 Selects Output Voltage Monitor Range
- 6 Selects Output Current Monitor Range
- 7 Selects Remote Shutdown Logic
- 8 Selects Over Temperature Shutdown Reset Mode

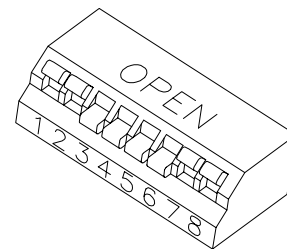

**Figure 4.2-1 Programming and Monitoring SW1 Switch**  
(Switch is shown in factory default configuration.)

**4.2.1 Rear Panel SW1 Switch (continued)**

The rear panel SW1 switch is marked with the word OPEN on its upper surface. Any of the eight switches on SW1 is OFF when it has been flipped up to break contact, ON when flipped down to close contact. Table 4.2-1 shows the functions assigned to each SW1 switch.

<b>Table 4.2-1 Rear Panel SW1 Switch Assignments (Factory Defaults Underlined)</b>			
<b>Switch</b>	<b>Function</b>	<b>Open</b>	<b>Closed</b>
SW1-1	1mA current source for resistive programming of output voltage	<u>Voltage source programming</u>	Resistive programming (0-5k, 0-10k)
SW1-2	1mA current source for resistive programming of output current limit	<u>Voltage source programming</u>	Resistive programming (0-5k, 0-10k)
SW1-3	Output voltage programming source range select	0-5V (0-5k)	<u>0-10V</u> (0-10k)
SW1-4	Output current limit programming source range select	0-5V (0-5k)	<u>0-10V</u> (0-10k)
SW1-5	Output voltage monitor range select	0-5V	<u>0-10V</u>
SW1-6	Output current monitor range select	0-5V	<u>0-10V</u>
SW1-7	Remote shutdown logic select	<u>HIGH=OFF</u>	HIGH=ON
SW1-8	Over temperature shutdown reset mode select	<u>Auto reset</u>	Latch OFF

**Resetting the Switches**

Before making any changes to the switch settings, disable the power supply output by pushing the front panel STANDBY switch to its IN position. This shuts down the power supply on a temporary basis. The front panel S/D LED turns on. Then, use any small, flat-bladed screwdriver to change the switch settings.

**4.2.2 Rear Panel J2 Connector**

The J2 Programming and Monitoring connector is a 15-terminal wire clamp connector located on the power supply's rear panel. See Figure 4.2-2. The J2 connector provides access to the following functions:

- Remote programming of output voltage AND/OR current limit
- Remote monitoring of calibrated readback signals for output voltage and output current
- Remote control of the shutdown function using a 2.5 to 15V signal

- 1 Remote Output Voltage Programming Select
- 2 Remote Output Current Limit Programming Select
- 3 Control Ground
- 4 No connection
- 5 Voltage Program Signal Return
- 6 Output Voltage Programming Input
- 7 Current Program Signal Return
- 8 Output Current Limit Programming Input
- 9 Voltage Monitor Signal Return
- 10 Output Voltage Monitor
- 11 Current Monitor Signal Return
- 12 Output Current Monitor
- 13 No connection
- 14 Shutdown (S/D) Signal Return (-)
- 15 S/D Input (+)

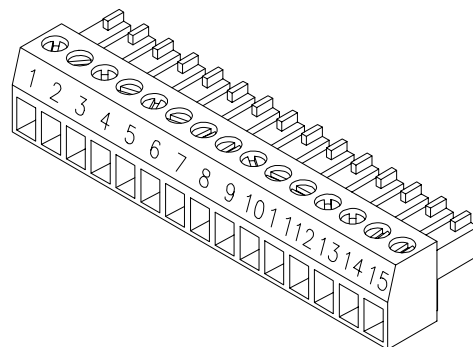

**Figure 4.2-2 Programming and Monitoring J2 Connector**

### 4.2.3 Rear Panel J2 Connector (continued)

See Table 4.2-2 for the list of the J2 connector terminal numbers, their labels, and corresponding functions.

<b>Table 4.2-2 Rear Panel J2 Connector Terminals and Functions</b>			
<b>Connector</b>	<b>Label</b>	<b>Name</b>	<b>Function</b>
J2-1	VRMT	Remote Output Voltage Programming Select	Selects remote output voltage programming when jumpered to pin 3.
J2-2	IRMT	Remote Output Current Limit Programming Select	Selects remote output current limit programming when jumpered to pin 3.
J2-3	CNTL GND	Control Ground	Control ground.
J2-4	N/C	No connection	None.
J2-5	VPGM –	Voltage Program Signal Return	Return for voltage program signal.
J2-6	VPGM	Output Voltage Programming Input	Input for voltage programming signals from an analog device.
J2-7	IPGM –	Current Program Signal Return	Return for current program signal.
J2-8	IPGM	Output Current Limit Programming Input	Input for current limit programming signals from an analog device.
J2-9	VMON –	Voltage Monitor Signal Return	Return for voltage monitor signal.
J2-10	VMON	Output Voltage Monitor	Output for output voltage monitor signal.
J2-11	IMON –	Current Monitor Signal Return	Return for current monitor signal.
J2-12	IMON	Output Current Monitor	Output for output current monitor signal.
J2-13	N/C	No connection	None.
J2-14	S/D –	Shutdown Signal Return (-)	Return for shutdown signal.
J2-15	S/D	S/D Input (+)	Input for shutdown signal.

#### **Making J2 Connections**

##### **CAUTION**

Do not attempt to bias program/monitor signal return (J2 terminals 5, 7, 9, and 11) relative to the supply output because control ground (J2-3) and the program/monitor signal returns are at the same potential as the power supply return in a standard unit. Use the Isolated Programming (ISOL) Interface option to allow control from a programming source at a different potential relative to the supply's output.

##### **CAUTION**

To maintain the isolation of the power supply output and prevent ground loops, use an isolated (ungrounded) programming source when operating the power supply via remote analog control at the J2 connector.

Make connections to the J2 connector using its screw-type wire clamps. Before making any connections, turn the power supply OFF and wait until the front panel displays have gone out. You can unplug the connector from the back of the unit in order to make it easier to install the required wiring.

#### **Wiring**

Use any suitable wire such as 16 to 24 AWG stranded wire for most connections, but we recommend that you use shielded twisted pair wiring for applications which require low noise performance. Strip wires 0.26" (6.5 mm) and insert securely, as with any wire clamp connector.



### 4.3 Remote Analog Programming of Output Voltage and Current Limit

Remote analog programming allows control of the power supply's output voltage and/or current limit to shift from local operation at the front panel voltage and current controls to external analog sources. As you vary the external programming source, the power supply's output varies proportionally over its output range.

Using remote analog programming requires that you reset switch SW1 and make connections to the J2 connector on the power supply's rear panel. See Section 4.2 Switches and Connector Used for Remote Programming and Monitoring.

#### 4.3.1 Remote Programming Options

See Table 4.3-1 for a summary of the options available to you for programming output voltage and current limit using an analog source.

Table 4.3-1 Remote Programming Options	
Control of ...	Programming Scales *
Output Voltage and/or	0-5V and 0-10V voltage sources
Current Limit	0-5kΩ and 0-10kΩ resistances

\* These scales may be used in any combination.

Refer also to Section 4.5 for information about the Isolated Programming (ISOL) Interface option for 4-channel control of your unit.

#### 4.3.2 Remote Analog Programming Procedure

**CAUTION**

To maintain the isolation of the power supply output and prevent ground loops, use an isolated (ungrounded) programming source when operating the power supply via remote analog control at the J2 connector.

**CAUTION**

The remote programming inputs are internally referenced to the supply's negative output. Do not connect control ground (J2 terminals 3, 5, or 7) to the supply's positive output.

1. Shut the power supply OFF.
2. Set switches SW1-1, SW1-2, SW1-3, and SW1-4 according to the programming sources you will be using, as indicated in Table 4.3-2. See Notes at the end of this procedure for more information about switch settings.
3. Install any J2 connector jumpers as indicated in Table 4.3-2.
4. Connect the programming source(s) to the mating J2 connector as shown in Figure 4.3-1, observing the correct polarity for voltage sources. Ensure that the mating connector is plugged securely into the rear panel connector.
5. Set the programming sources to the desired levels and turn the power supply ON. The REM LED turns on. Adjust the external programming source to change the power supply's output.

**4.3.2 Remote Analog Programming Procedure (continued)**

Notes:

1. The rear panel SW1 switch is marked with the word OPEN on its upper surface. Any of the eight switches on SW1 is OFF when it has been flipped up to break contact, ON when flipped down to close contact.
2. Resetting switches SW1-3 or SW1-4, the programming scale selection switches, may require that you recalibrate the programming circuit to maintain programming accuracy. See Section 5. Calibration.
3. Switches SW1-5, SW1-6, SW1-7, and SW1-8 are not required for remote programming. They remain at the settings you have selected for your application.
4. Switches SW-1 to SW-4 can be set to their defaults (1 and 2 open, 3 and 4 closed) unless otherwise specified in Table 4.3-2. See Section 4.2.1 Rear Panel SW1 Switch for default settings.

<b>Table 4.3-2 Power Supply Settings for Different Programming Sources</b>					
<b>Output Voltage Programming Source</b>	<b>Output Current Limit Programming Source</b>				
	<b>0-5Vdc</b>	<b>0-10Vdc</b>	<b>0-5kΩ Resistor</b>	<b>0-10kΩ Resistor</b>	<b>None (Front Panel Control)</b>
<b>0-5Vdc</b>	SW1: 3 and 4 open. J2 Jumper: 1 to 3 and 2 to 3.	SW1: 3 open. J2 Jumper: 1 to 3 and 2 to 3.	SW1: 2 closed, 3 and 4 open. J2 Jumper: 1 to 3 and 2 to 3.	SW1: 2 closed, 3 open. J2 Jumper: 1 to 3 and 2 to 3.	SW1: 3 open. J2 Jumper: 1 to 3.
<b>0-10Vdc</b>	SW1: 4 open. J2 Jumper: 1 to 3 and 2 to 3.	SW1: default settings. J2 Jumper: 1 to 3 and 2 to 3.	SW1: 2 closed, 4 open. J2 Jumper: 1 to 3 and 2 to 3.	SW1: 2 closed. J2 Jumper: 1 to 3 and 2 to 3.	SW1: default settings. J2 Jumper: 1 to 3.
<b>0-5kΩ Resistor</b>	SW1: 1 closed, 3 and 4 open. J2 Jumper: 1 to 3 and 2 to 3.	SW1: 1 closed, 3 open. J2 Jumper: 1 to 3 and 2 to 3.	SW1: 1 and 2 closed, 3 and 4 open. J2 Jumper: 1 to 3 and 2 to 3.	SW1: 1 and 2 closed, 3 open. J2 Jumper: 1 to 3 and 2 to 3.	SW1: 3 open, 1 closed. J2 Jumper: 1 to 3.
<b>0-10kΩ Resistor</b>	SW1: 1 closed, 4 open. J2 Jumper: 1 to 3 and 2 to 3.	SW1: 1 closed. J2 Jumper: 1 to 3 and 2 to 3.	SW1: 1 and 2 closed, 4 open. J2 Jumper: 1 to 3 and 2 to 3.	SW1: 1 and 2 closed. J2 Jumper: 1 to 3 and 2 to 3.	SW1: 1 closed. J2 Jumper: 1 to 3.
<b>None (Front Panel Control)</b>	SW1: 4 open. J2 Jumper: 2 to 3.	SW1: default settings. J2 Jumper: 2 to 3.	SW1: 2 closed, 4 open. J2 Jumper: 2 to 3.	SW1: 2 closed. J2 Jumper: 2 to 3.	SW1: default settings. J2 Jumper: none.

**4.3.2 Remote Analog Programming Procedure (continued)**

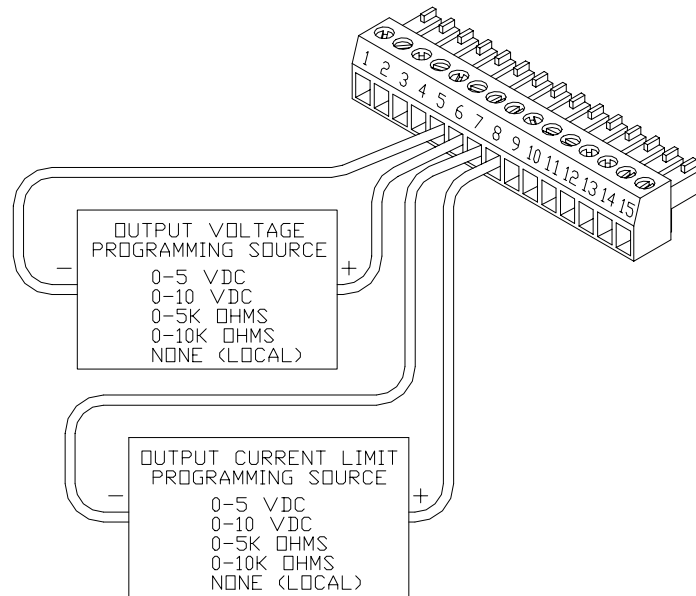

**Figure 4.3-1 Connecting Programming Sources to J2 Connector**

**4.4 Remote Monitoring of Output Voltage and Current**

**4.4.1 Readback Signals**

The J2 connector on the rear panel provides access to calibrated readback signals for remote monitoring of the output voltage and current. Rear panel switches SW1-5 and SW1-6 allow you to select either a 0-5Vdc or a 0-10Vdc range for the output. The readback signal represents 0 to 100% of the power supply's output.

See Table 4.4-1 for the required J2 connections and switch settings for remote monitoring of readback signals with 0-5Vdc or 0-10Vdc outputs. Use shielded-twisted pair wiring (20 to 24 AWG) and ground the shield to J10 sense connector terminal 1 (return sense) or to the chassis.

<b>Table 4.4-1 Power Supply Settings for Remote Monitoring of Readback Signals</b>					
<b>Readback Signal</b>	<b>J2 Connections</b>		<b>Switch SW1 Settings</b>		<b>Output Signal Range</b>
	<b>Signal (+)</b>	<b>Return (-)</b>	<b>Switch #</b>	<b>Setting</b>	
Output Voltage	Terminal 10	Terminal 9	SW1-5	OPEN	0-5Vdc
				CLOSED	0-10Vdc
Output Current	Terminal 12	Terminal 11	SW1-6	OPEN	0-5Vdc
				CLOSED	0-10Vdc

Note: Check the readback accuracy any time you reset switches SW1-5 and SW1-6. See Section 5. Calibration.

## 4.5 Using the Isolated (ISOL) Programming Interface Option

The 4-channel Isolated (ISOL) Programming Interface allows remote programming and readback of the power supply output voltage and current limit using 0-5V analog signals that are not referenced to the power supply's internal ground. The isolation amplifiers used are rated to 1000Vdc. With ISOL installed, the power supply will no longer support resistive programming, or, 0-10V programming or readback. Any non-programmed function (either voltage or current limit) can still be controlled via the power supply's front panel.

### 4.5.1 ISOL Specifications

Table 4.5-1 Isolated (ISOL) Programming Interface Specifications					
Characteristics		Minimum	Typical	Maximum	Unit
Gain:	Nominal Gain	–	1	–	V/V
	Gain Error	–	±0.04	±0.03	% FSR
	Gain vs Temperature	–	-0.02	-0.06	%/°C
	Non Linearity	–	±0.08	±0.25	% FSR
Input:	Offset Voltage	–	±20	±50	mV
	Input vs Temperature	–	±25	±100	μV/°C
	Voltage Range	0	–	5	V
	Resistance	–	49	–	kΩ
Readback:	Voltage Range	0	–	5	V
	Current Drive	±5	±15	–	mA
	Load Capacitance	–	–	1	μF

### 4.5.2 ISOL Setup and Operating Instructions

#### CAUTION

In order to maintain isolation, do not connect either rear panel connector J2 terminal 3 (control ground) or the supply return to J2 terminals 5, 7, 9, or 11 (program/monitor signal returns).

1. Ensure that the power supply rear panel SW1 switches 3, 4, 5, and 6 are set for 0-5V programming and monitoring (Section 4.2).
2. Connect the 0-5V programming source or the monitor lines to the J2 connector on the power supply's rear panel as described in Table 4.5-1. Note: With ISOL installed, J2 connector terminals 5, 7, and 9 are disconnected. Use J2 connector terminal 11 for programming and monitoring return connections.
3. Once the connections are made, use the power supply with the ISOL interface installed as you would use a power supply with a 0-5Vdc programming source. The only differences are that the programming and monitoring sources are now isolated and that resistive and 0-10V programming as well as 0-10V monitoring are disabled. All front panel functions are as usual.

Table 4.5-1 J2 Programming and Monitoring Connections with ISOL Interface				
	Voltage Program (VPGM)	Current Program (IPGM)	Voltage Monitor (VMON)	Current Monitor (IMON)
Program Signal	J2-6	J2-8	J2-10	J2-12
Return	J2-11	J2-11	J2-11	J2-11

### 4.5.3 ISOL Calibration

To calibrate a unit which has the ISOL Interface installed, the service technician follows the standard procedures in Section 5. Calibration.

## 5. CALIBRATION

### 5.1 Introduction



#### **HIGH ENERGY/HIGH VOLTAGE WARNINGS**

Exercise caution when using and servicing a power supply. High energy levels can be stored at the output voltage terminals on a power supply in normal operation. In addition, potentially lethal voltages exist in the power circuit and on the output and sense connectors of a power supply with a rated output greater than 40V. Filter capacitors store potentially dangerous energy for some time after power is removed.

Adjustments to programming and readback accuracy for the power supply are made using cover-off procedures which must be performed by a service technician.

### 5.2 Calibration Setup

#### 5.2.1 Service Environment and Precautions

- Follow established antistatic procedures.
- Work at a bench with adequate room and support for the unit under test and for all equipment required.
- To reduce shock hazard, use only an insulated, straight-blade screwdriver when calibrating trim potentiometers.
- NEVER calibrate these units alone. Ensure that someone is present who can help should an accident occur.

#### 5.2.2 Equipment Required

You will need the following equipment when calibrating your power supply.

- 5 1/2 digit true RMS voltmeters (DVMs) ( $\pm 0.05\%$  accuracy) with test leads
- Current shunt 1mV/AMP ( $\pm 0.25\%$ ) and connecting wire. The recommended current ratings for the DC shunt and connecting wire must be at least 10% greater than the power supply's output current rating. See also Table 5.2-1.
- Non-conducting, straight-blade screwdriver

**Table 5.2-1 Current Carrying Capacity for Wiring**

Wire Size (AWG)	Maximum Current (A)	Wire Size (AWG)	Maximum Current (A)
20	2.5	6	61
18	4	4	97
16	6	2	155
14	10	1	192
12	16	1/0	247
10	21	2/0	303
8	36		

## 5.2 Calibration Setup

### 5.2.3 Accessing Calibration Potentiometers

**WARNING**

Disconnect AC power from the unit before removing the cover. Even when the front panel power switch is in the OFF position, live line voltages are exposed when the cover is removed. Repairs and adjustments must be made by experienced service technicians only.

**WARNING**

Use a non-conducting, straight-blade screwdriver to adjust the trim pots.

**CAUTION**

Follow established antistatic procedures. There are static-sensitive parts on the printed circuit boards.

You will need to remove the power supply's cover to access the programming and readback calibration potentiometers which are located on the A2 PCB. See Figure 5.2-1 to locate the potentiometers.

#### Removing Option Card

If there is a GPIB or RS-232 option card (PCB) installed inside the power supply, you will have to remove it to access the calibration potentiometers.

Tool Required: Phillips #2 screwdriver

1. Turn off the power supply. Disconnect AC Power. Remove the cover.
2. Remove 4 screws from their standoffs inside the power supply to release the option card.
3. Remove 2 screws at the rear panel to release the option card's sub-plate.
4. Unplug the ribbon cable connectors from the option card. Lift out card.

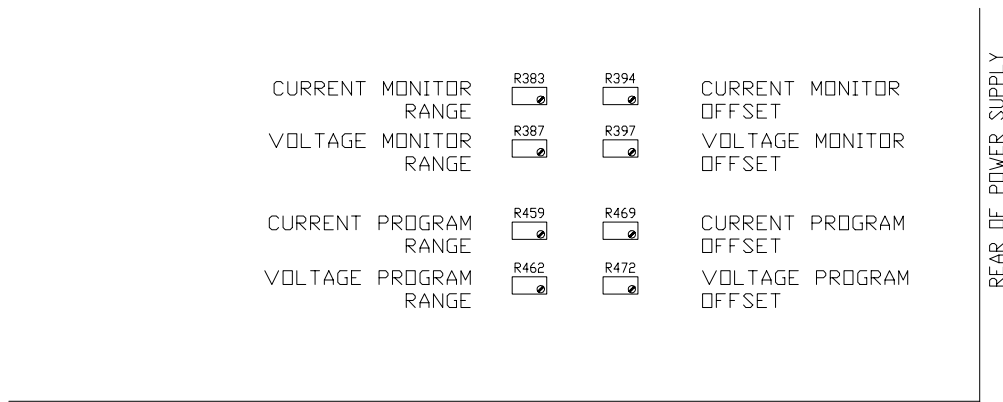

**Figure 5.2-1 Programming and Monitoring Calibration Locations**  
(Top view.)

## 5.3 Calibrating for Programming Accuracy

The factory calibrates the offset and range of the voltage and current programming circuits to within 1% for the default 0-10Vdc programming signals. You may need to recalibrate when you use 0-5Vdc programming or when you switch back to 0-10Vdc programming after previously calibrating for 0-5Vdc programming.

See Section 5.2 to remove the cover and any option card. Follow all procedure steps in the sequence given.

### 5.3.1 Voltage Programming Circuit Calibration

1. Ensure that the power supply is turned off. Disconnect any load.
2. Connect the program source between J2 connector terminals 6 (output voltage program input) and 5 (voltage program signal return).
3. Connect the DVM across the power supply output.
4. Turn the power supply on.
5. Apply 1% of program voltage.
6. Adjust the voltage program offset potentiometer (R472) until the DVM reads 1% of the model-rated output voltage.
7. Apply 100% of program voltage.
8. Adjust the voltage program range potentiometer (R462) until the DVM reads the model-rated output voltage.

Repeat this procedure until output levels are adjusted to power supply specifications (see Section 1) or to the accuracy that your application requires.

### 5.3.2 Current Limit Programming Circuit Calibration

1. Ensure that the power supply is turned off. Disconnect any load.
2. Connect the program source between J2 connector terminals 8 (output current limit programming input) and 7 (current program signal return).
3. Connect the shunt and DVM across the power supply output.
4. Turn the power supply on.
5. Apply 1% of program voltage.
6. Adjust the current limit program offset (R469) until the shunt/DVM indicates 1% of the model-rated output current. See Note.
7. Apply 100% of program voltage.
8. Adjust the current limit program range (R459) until the shunt/DVM indicates the model-rated output current. See Note.

Repeat this procedure until output levels are adjusted to power supply specifications (see Section 1) or to the accuracy that your application requires.

Note: Calculate the required DVM reading using  $V = IR$  where V is the DVM reading, I is the current, and R is the DC shunt resistance.

## 5.4 Calibrating for Readback Accuracy

The factory calibrates the offset and range of the output voltage and current monitor circuits to within 1% for the default 0-10Vdc scales. You may need to recalibrate when you select the 0-5Vdc scale or when you switch back to the 0-10Vdc scale after previously calibrating for 0-5Vdc operation.

See Section 5.2 to remove the cover and any option card. Follow all procedure steps in the sequence given.

### 5.4.1 Output Voltage Monitor Circuit Calibration

1. Ensure that the power supply is turned off. Disconnect any load.
2. Set SW1 switch 5 OPEN to select 0-5V output voltage monitor range, CLOSED for 0-10V.
3. Connect a DVM across the power supply output to read the output voltage. Connect a second DVM between the rear panel J2 connector terminals 10 (output voltage monitor) and 9 (voltage monitor signal return).
4. Turn the power supply on.
5. Set the power supply output voltage to 1% of the model-rated output.
6. Adjust the output voltage monitor offset (R397) until the monitor DVM reads 1% of the readback scale. (50mVdc for 0-5V readback or 100mVdc for 0-10Vdc readback.)
7. Set the power supply output voltage to the model-rated maximum.
8. Adjust the output voltage monitor range (R387) until the monitor DVM reads 100% of the readback scale. (5Vdc for 0-5V readback or 10Vdc for 0-10Vdc readback.)

Repeat this procedure until the monitor signal is adjusted to power supply specifications (see Section 1) or to the accuracy that your application requires.

### 5.4.2 Output Current Monitor Circuit Calibration

1. Ensure that the power supply is turned off. Disconnect any load.
2. Set SW1 switch 6 OPEN to select 0-5V output current monitor range, CLOSED for 0-10V.
3. Connect the shunt and DVM across the power supply output to read the output current. Connect a second DVM between the rear panel J2 connector terminals 12 (output current monitor) and 11 (current monitor signal return).
4. Turn the current control fully counter clockwise, then turn on the power supply.
5. Set the power supply's output current to 1% of the model-rated output. See Note.
6. Adjust the output current monitor offset (R394) until the monitor DVM indicates 1% of the readback scale. (50mVdc for 0-5V readback or 100mVdc for 0-10Vdc readback.)
7. Set the power supply output current to the model-rated output.
8. Adjust the output current monitor range (R383) until the monitor DVM indicates 100% of the readback scale. (5Vdc for 0-5V readback or 10Vdc for 0-10Vdc readback.)

Repeat this procedure until the monitor signal is adjusted to power supply specifications (see Section 1) or to the accuracy that your application requires.

Note: Calculate the required DVM reading using  $V = IR$  where V is the DVM reading, I is the current, and R is the DC shunt resistance.





Xantrex Technology Inc.  
8587 Baxter Place  
Burnaby, B.C.  
Canada V5A 4V7

Tel: 604-415-4600  
Fax: 604-415-4674

Toll Free North America  
1-800-667-8422

e-mail: [xantrex@xantrex.com](mailto:xantrex@xantrex.com)  
<http://www.xantrex.com>

**XANTREX**  
The Power To Rely On